

7948

Handbook for District Sanitation Coordinators

Kedadire Basaako
Ronald D. Parker
Robert B. Waller
James G. Wilson

Edited by John van Nostrand

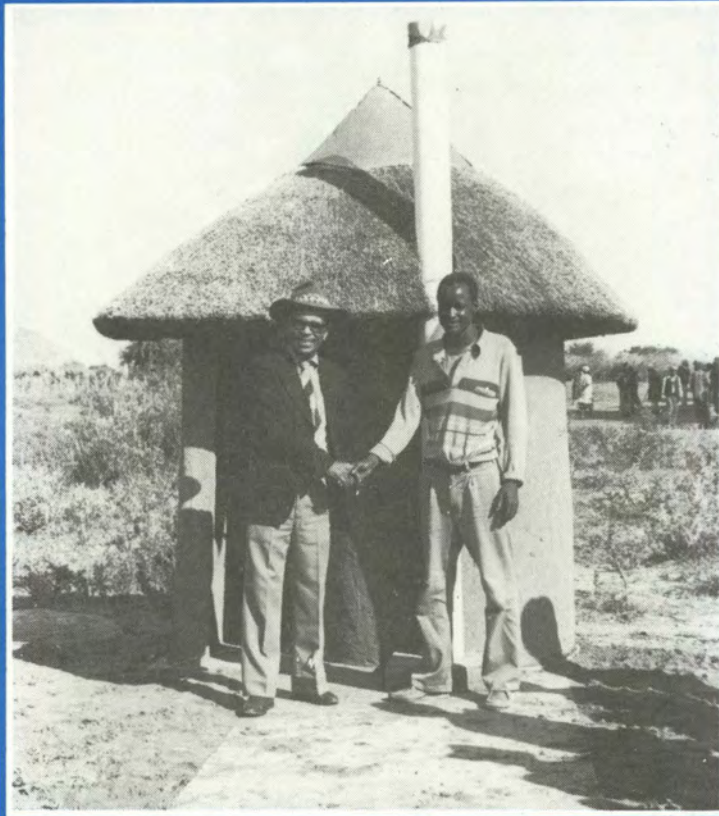

A joint contribution of the Government of Botswana, The United Nations Development Programme, and The World Bank to the International Drinking Water Supply and Sanitation Decade.

AMER#
7948

Handbook for District Sanitation Coordinators

Authors: Keadire Basaako
Ronald D. Parker
Robert B. Waller
James G. Wilson

Editor: John van Nostrand

ACKNOWLEDGEMENTS

The authors wish to acknowledge, with thanks, the advice and assistance of the Council Secretaries and Staff of Kgatleng and Southern Districts, the United States Agency for International Development (USAID), and the Technology Advisory Group (TAG) operating under the United Nations Development Programme Interregional Project INT/81/047 (executed by the World Bank).

INTRODUCTION TO TAG REPRINT COPY

The "Handbook for District Sanitation Coordinators" was originally prepared by two members of the USAID-funded team that had assisted in the development and implementation of the Environmental Sanitation and Protection (ESPP) Pilot Project in Botswana. TAG has been closely involved with ESPP since its inception, through participation in USAID project development missions and through technical support to the Senior Public Health Engineer (SPHE) in the Ministry of Local Government and Lands (MLGL) - an expatriate provided by UNDP through its project BOT/79/003. The SPHE supervised the project. TAG missions and headquarters staff were also responsible for the editing and production of the handbook.

In view of the success of the rural sanitation programme in Botswana, which may provide a valuable model for other areas in the developing world, TAG has arranged, with the agreement of the Government of Botswana, to reprint the handbook so as to make it widely available to those concerned with the planning, design and implementation of rural sanitation programmes.

Comments and suggestions on the publication should be addressed to the Project Manager, UNDP Project INT/81/047, Water Supply and Urban Development Department, The World Bank, 1818 H Street N.W., Washington, D.C. 20433, U.S.A.

Copyright © 1983

The International Bank for Reconstruction and
Development/THE WORLD BANK
1818 H Street, N.W.
Washington, D.C. 20433, USA

All rights reserved

ACRONYMS

ACDO	Assistant Community Development Officer
BOTVIP	Ventilated, Improved Single-Pit Latrines used in Botswana
CFDA	Communal First Development Area
CPO	Council Planning Officer
DET	District Extension Team
DGS	Department of Geological Surveys
DO	District Officer
DSC	District Sanitation Coordinator
DSF	District Sanitation Foreman
DSPC	District Sanitation Planning Committee
DWA	Department of Water Affairs
ESPP	Environmental Sanitation and Protection Project
FWE	Family Welfare Educator
MLGL	Ministry of Local Government and Lands
REC II	Revised Earth Closet Type II Latrine
RO	Revenue Officer
RIO	Rural Industries Officer
ROEC	Reeds Odourless Earth Closet
SCDO	Senior Community Development Officer
SPHE	Senior Public Health Engineer
SWF	Senior Works Foreman
SWO	Senior Water Officer
TAG	Technology Advisory Group of The World Bank
USAID	United States Agency for International Development
VDC	Village Development Committee
VET	Village Extension Team
VSA	Village Sanitation Assistant
VSC	Village Sanitation Coordinator

Contents

Map: Location of ESPP Pilot Project Villages	2
1.0 INTRODUCTION	7
2.0 BACKGROUND	9
2.1 Programme Objectives	10
2.2 History of the Environmental Sanitation and Protection Pilot Project	11
3.0 SETTING UP THE DISTRICT PROGRAMME	15
3.1 District Sanitation Planning Committee	16
3.2 Tour of Previously Improved Villages	18
3.3 Selection of Villages to Be Improved	19
3.4 District Sanitation Plan	22
3.5 Logistics	24
3.6 Dissemination of Information	25
3.7 Other Agencies	27
4.0 THE PROGRAMME TEAM	29
4.1 Senior Public Health Engineer	30
4.2 District Sanitation Coordinator	31
4.3 District Sanitation Foreman	32
4.4 Village Sanitation Coordinator	33
4.5 Village Sanitation Assistants	35
4.6 Village Development Committee/ Village Extension Team	37
5.0 LATRINE DESIGN AND CONSTRUCTION	39
5.1 Latrine Design	40
5.2 Latrine Construction	42
6.0 VILLAGE IMPLEMENTATION	47
6.1 Meetings and Handouts	48
6.2 Village Baseline Survey	51
6.3 Selection of Latrine Design	52
6.4 Demonstration Latrines	54
6.5 Construction Training	56
6.6 Household Latrine Construction	58
6.7 Payment by Village Residents	60
6.8 Revenue Collection	62
6.9 Stores Controls	63
6.10 Payment of Village Staff	64
6.11 Purchasing	66
7.0 MONITORING THE PROGRAMME	67
8.0 APPENDICES	71
9.0 FIGURES	101

Handbook for District Sanitation Coordinators

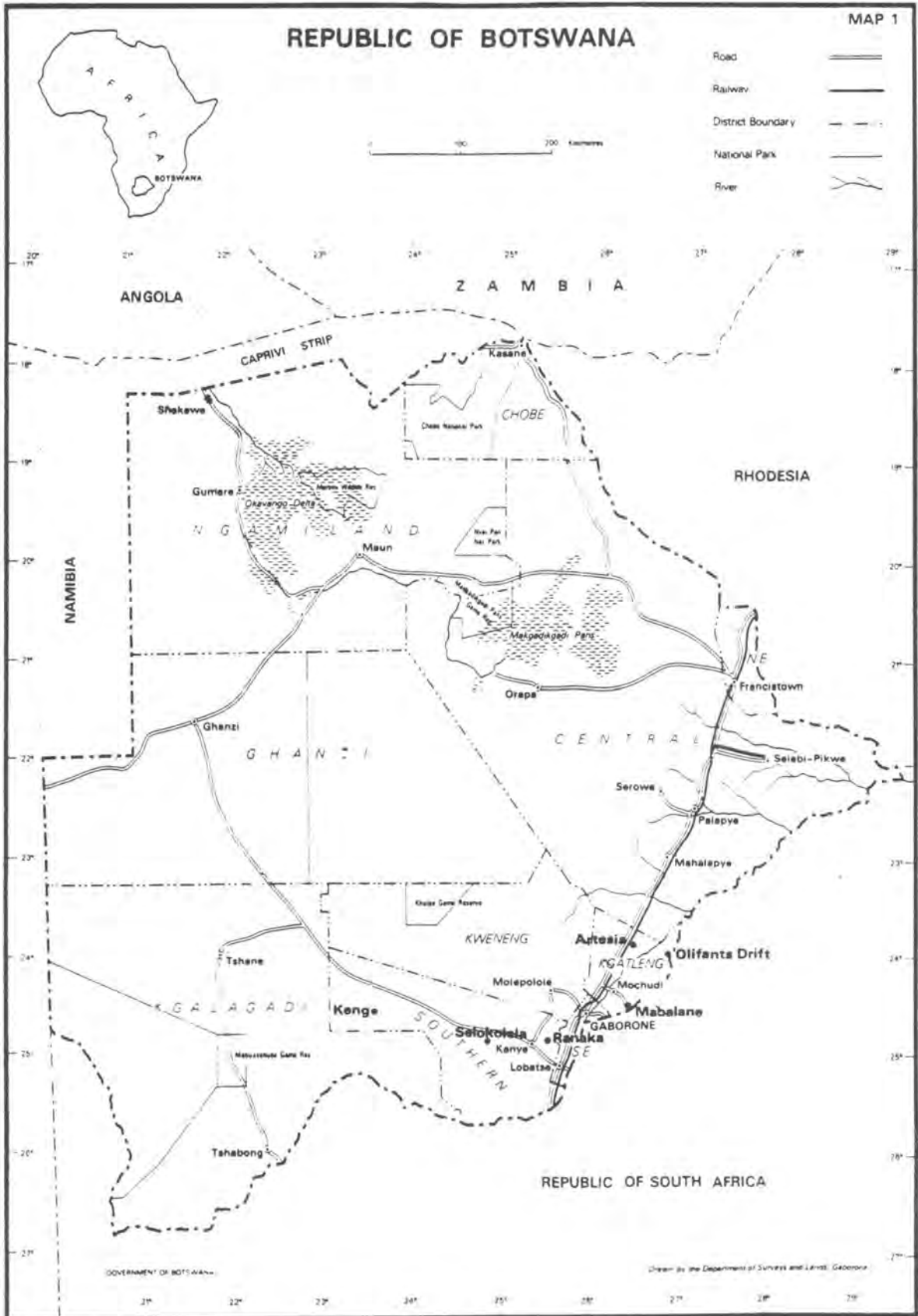

1.0 Introduction

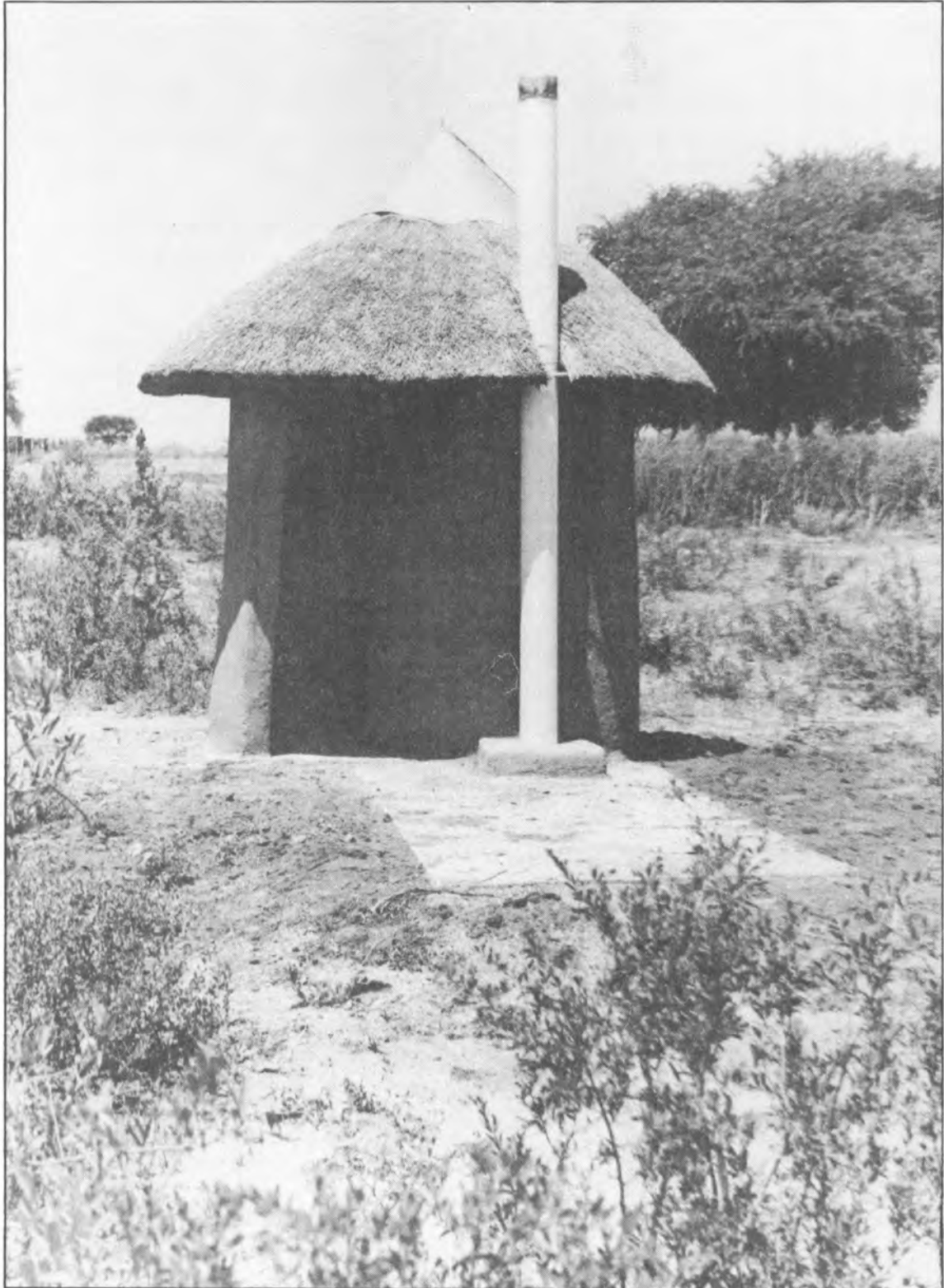

1.0 Introduction

This handbook is written for the use of District Sanitation Coordinators (DSCs) charged with designing and implementing District Sanitation Programmes in Botswana. These programmes form part of the National Rural Sanitation Programme, which is administered by the office of the Senior Public Health Engineer in the Ministry of Local Government and Lands. As the handbook is quite detailed, it may prove useful to other members of the implementation team, particularly those working within the individual villages.

Botswana's current rural sanitation programme is derived, to a great extent, from the Environmental Sanitation and Protection (ESPP) Pilot Project (hereafter referred to as the Pilot Project) which was funded by the United States Agency for International Development and administered through the Ministry of Local Government and Lands between 1980 and 1982. Indeed, the contents of this handbook are largely drawn from the experience of this Pilot Project. A brief history of the project is presented in the first sections of this handbook so that newly appointed DSCs might familiarize themselves with it.

Following this historical outline, the handbook presents a step-by-step description of those components of the District Sanitation Programme for which the DSCs will be either directly or indirectly responsible. The components are arranged in the order in which they are likely to be encountered when actually implemented in the field.

In addition, each component is broken into three parts:

first, a "Recommendation" to the DSCs on what needs to be done;

second, an "Elaboration" of the recommendation, which presents a more detailed

outline of the objectives of the component; and

third, a summary of the "Pilot Project Experience," which gives a brief history of the initial team's experience so that, among other things, its efforts and experiments will not be repeated unnecessarily.

In other words, the handbook is composed of the Pilot Project team's recommendations to the DSCs on how best to implement the District Sanitation Programme. While it is hoped that these recommendations will serve as useful guidelines for the DSCs, ultimately the DSCs will have to make final decisions based not only on previous experience but also on the nature of the problems immediately confronting them. This being the case, there will be a need to revise and improve the handbook after it has been used in the field for a couple of years.

2.0 Background

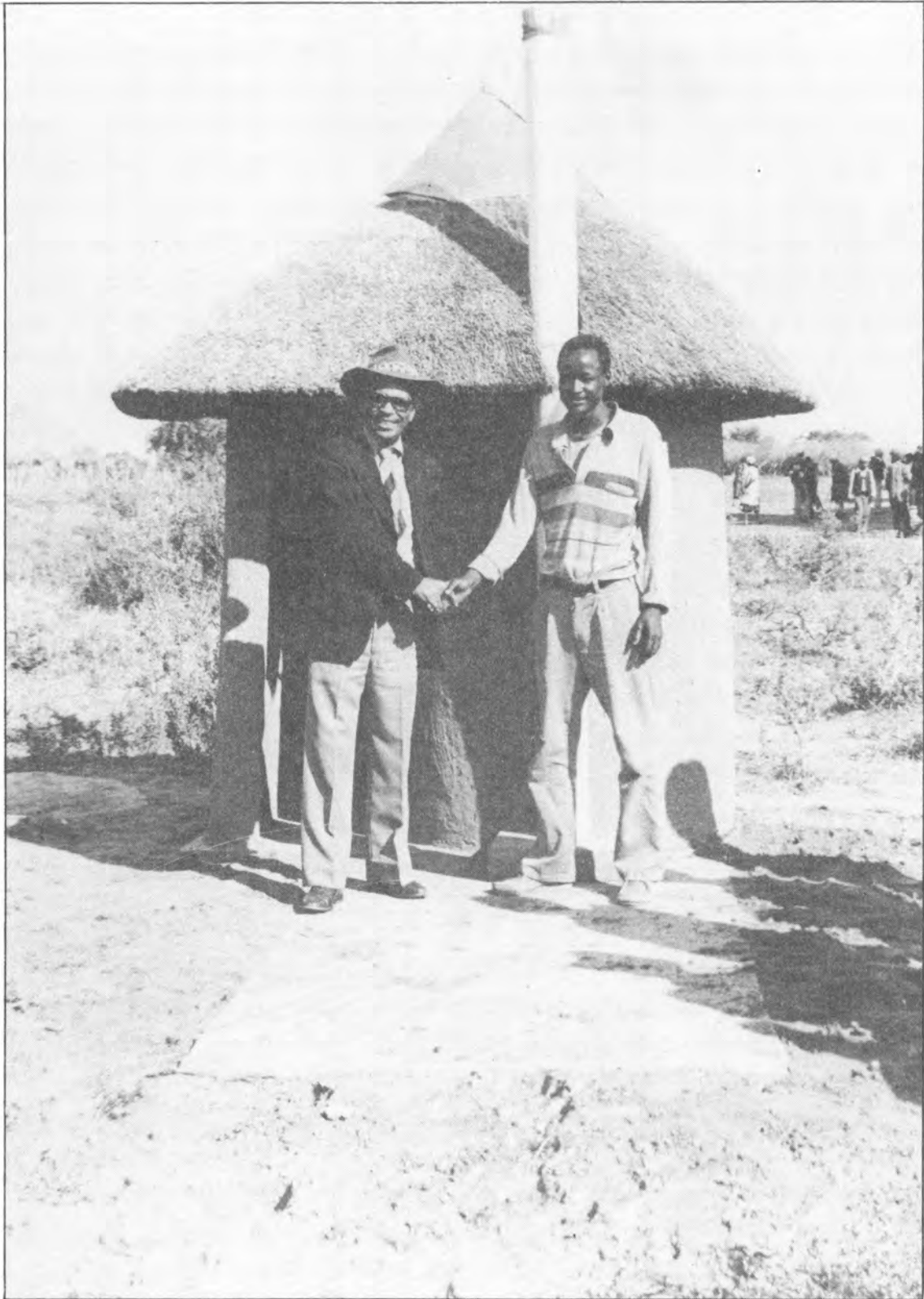

2.1 Programme Objectives

In both rural and urban areas of Botswana, the Batswana share a common goal — improved health for themselves and their families. Many already understand the relationship between improved community sanitation and better health. Many would like to have a private latrine for their household. However, many also lack the knowledge and funds required to build one. In addressing these conditions, the broadest goal of the District Sanitation Programme is to improve rural standards of health through a reduction in diseases caused by poor sanitation. More specifically, the programme seeks to prevent the indiscriminate dispersal of human excreta throughout villages by giving householders who do not, at present, own or use a latrine better access to the funds and knowledge required to build one. Ultimately, the programme seeks to promote strong, healthy families capable of working and contributing to rural society. The success of this programme will rely on the ability and persistence of District Councils, village leaders and extension workers to stress the significance of improved sanitation.

2.2 History of the Environmental Sanitation and Protection Pilot Project

The Environmental Sanitation and Protection (ESPP) Pilot Project served as the test case for the current rural sanitation programme. A brief outline of it is presented here so that the District Sanitation Coordinators (DSCs) may familiarize themselves with the historical development of this programme.

The ESPP Pilot Project was initiated by the Government of Botswana and rural residents in recognition of the growing number of health problems associated with inadequate personal and community sanitary practices in rural areas. In particular, it was clear that most diarrhoeal and intestinal diseases, including cholera, could be attributed largely to improper disposal of human excreta.

The need for some form of improvement was first voiced at the National Conference of District Development Committees in 1976, which resolved that a coordinated effort, on a national level, was necessary to improve sanitation. This need was reiterated at the local level in the "Needs Assessment" which was prepared for Southern District by the Rural Industries Innovation Centre in 1978. The survey carried out in association with this study indicated that rural residents considered sanitation to constitute one of their most urgent needs.

Responding to this expressed need, the Government of Botswana requested assistance from the United States Agency for International Development (USAID) in implementing an experimental, village-based pilot project which would

develop, test and evaluate various educational techniques, media and messages related to sanitation and the building and maintenance of appropriate latrines and refuse disposal systems; and test various types of latrines and refuse disposal systems to determine which ones are

technically appropriate, socially acceptable and affordable to rural householders.¹

Project staff were also asked to look at the ways in which the Pilot Project could be replicated afterwards on a national basis, moving from one District to another. Here the Government of Botswana requested that the Pilot Project

lay the groundwork for a package which may be used in any District and which can be implemented at a decentralized level by local authorities in accordance with the government's emphasis on District development planning when the Districts define the problem as a priority and are willing to commit resources to it.²

In 1979, a multidisciplinary team of USAID consultants met with the Government of Botswana to set up an initial design for the Pilot Project. Together, they produced the final "Project Paper," which contained a detailed plan of action for carrying out the project. Two Districts — Southern and Kgatleng — were chosen for pilot implementation, as both had already selected sanitation as a development priority. The project got under way the following year with the arrival, in the field, of the Pilot Project team, which had been recruited by USAID and approved by the Government of Botswana.

The Pilot Project team began its work immediately by holding a four-day-long seminar at the Rural Industries Innovation Centre in Kanye. The purposes of the seminar were to discuss rural sanitation needs and the ways in which the project could be implemented. It was well attended and produced both a definition of the problem and a preliminary list of development strategies, as well as methods for achieving them.

¹ Environmental Sanitation and Protection Project Design Team, "Project Paper," 1979.

² Ibid.

The first task for the Pilot Project team was identified as the development of latrine designs which were "appropriate" to the villages to be served. The original Project Paper had recommended that three types of latrines be adopted: the Ventilated Improved Single-Pit (BOTVIP), the Reeds Odourless Earth Closet (ROEC) and the Revised Earth Closet Type II (REC II). The latter is a ventilated double-pit latrine. It was originally envisaged that these would be built by village residents themselves, with materials and technical assistance provided by the District Council. In fact, as will emerge later in this handbook, the eventual ESPP Pilot Project designs were based largely on the BOTVIP model alone. This was adopted to cut down on costs and simplify training and construction techniques.

The second task undertaken by the Pilot Project team was to review the list of pilot villages which had previously been selected by the District Councils (see Section 3.3). The villages eventually selected were Artesia, Mab-alane and Olifants Drift in Kgatleng District, and Ranaka, Selokolela and Keng in Southern District. A baseline social survey was completed on these villages in early 1980.

The third task initiated by the Pilot Project team was the development of the educational component of the project. Materials were needed that would demonstrate the advantage of improved sanitation to the householders. Materials were produced for Family Welfare Educators which illustrated the relationship between health and sanitation. Booklets were produced for village residents which gave a step-by-step guide to building one's own latrine or digging a refuse pit.

The latrine designs and educational materials were distributed, monitored and tested in each of the six pilot villages. As a result, revisions and improvements were made to them on an ongoing basis. For example, in Keng, most of Selokolela and a small part of

Ranaka, it was discovered that sandy soils were incapable of supporting the weight of the superstructure above the pit. Thus, the sub-structures were strengthened, at an extra cost. Similarly, it was originally proposed that the team build low-, medium- and high-cost demonstration models in each of the villages. However, the high-cost version was soon abandoned, as it was felt that anyone who could afford one had probably already built it, and the team did not feel that the quality of the high-cost latrines was so much better that it justified the added expense.

Once the designs and construction methods were selected for the latrines, demonstration models were built in the six pilot villages by Village Sanitation Assistants (VSAs). Villagers were invited to watch the construction process, since they would later have to decide if they wished to build a latrine for themselves.

Concurrent with the building of demonstration latrines, village groups were organized by the Pilot Project team to address the problem of litter in the village. These groups listened to cassette tapes prepared by the Pilot Project team on the subject of litter. They then dug refuse pits at each group member's house and, in some villages, organized litter pick-up campaigns. These moves were well received in most villages and resulted in the digging and utilization of refuse pits on most plots.

When the demonstration latrines were completed, *Kgotla* meetings (see Section 3.6) were held to talk about them. The building process and cost were explained, and all interested householders were asked to sign contracts. These contracts stipulated how much the householder would pay and what he/she would receive in return. Approximately 250 contracts were signed by householders in the six villages. The District Sanitation Foreman and VSAs then began visiting each of these people to complete the Council's portion of the construction and to encourage payment. Once this was completed, the VSAs

worked exclusively on encouraging the householder to complete his/her walls and roof and to finalize payment. Construction was completed by approximately half of those who had signed contracts before the rains began and people returned to the lands to plough.

The Pilot Project team immediately began summarizing and recording project experience for use by the Districts in continuing the

programme in new villages. This handbook brings together much of this information. What follows are the steps which should be followed in designing and implementing a District Sanitation Programme.

3.0 Setting Up the District Programme



3.1 District Sanitation Planning Committee

Recommendation

A District Sanitation Planning Committee should be set up at the outset of the programme under the secretaryship of the District Sanitation Coordinator. This Committee should meet on an *ad hoc* basis, as required, and report to the District Extension Team.

The Committee should include the Senior Public Health Engineer, the District Sanitation Coordinator, the Council Planning Officer, the Senior Water Officer (or Senior Works Foreman, whichever is more appropriate), the Paramount Chief or his delegate, and, where appropriate, the Communal First Development Area Coordinator.

Elaboration

Proper implementation of the District Sanitation Programme calls for the establishment of effective lines of communication between the various parties involved. The creation of the District Sanitation Planning Committee is critical to establishing these lines as early as possible. In order to speed up its work, the Committee should meet on an *ad hoc* basis, that is, whenever it is necessary to do so and there is something to discuss. The Committee could meet weekly or biweekly during the early stages of the programme and monthly later on (see Figure 2).

The principal task for the Committee is the production of a detailed District Sanitation Plan (see Section 3.4). This plan will guide sanitation development in the District as a whole. In addition, the Committee should monitor ongoing progress of the programme.

The following people should comprise this Committee:

Senior Public Health Engineer (SPHE)

The SPHE is in the Ministry of Local Government and Lands. His office can place the District's programme within the national context. In addition, he arranges national financing for sanitation and has considerable expertise and experience in the field.

District Sanitation Coordinator (DSC)

The DSC should serve as Secretary of the District Sanitation Planning Committee. He is also responsible for administering the District Sanitation Plan. Finally, he supervises District and local village staff associated with the programme.

Council Planning Officer (CPO)

The CPO is responsible for comprehensive planning in the District. Therefore, he should be included in order to ensure that the sanitation programme is integrated with other Council projects. Also, should additional financing be required, the CPO will be responsible for preparing the Project Memoranda or Addenda.

Senior Water Officer (SWO) / Senior Works Foreman (SWF)

The SWO (or SWF, depending on which department the programme falls under) will be required to assist the DSC in ongoing implementation of the programme.

The Paramount Chief

The Paramount Chief or his delegate represents the senior tribal authority on the Committee, and his participation in the early planning stages is critical to the project's future acceptance in particular villages and its eventual success.

The Communal First Development Area (CFDA) Coordinator

The CFDA Coordinator should be included on the Committee if any of the villages identified for improvement fall within the CFDA in the District. He should ensure that the sanitation component is well coordinated with other CFDA projects.

The Committee may wish to invite other persons to attend its meetings from time to time as it sees fit. However, the DSC should ensure that the Committee does not become unwieldy.

Pilot Project Experience

An ESPP Committee was formed in Southern District to monitor project activities. It was composed of the District Officer (Committee Chairperson and Southern District Coordinator), the Pilot Project team, the District Officer (Development), the Adult Education Officer, the Personnel Officer, the Regional Health Inspector and the Senior Nursing Sister.

The Committee met every other month during the first year of the Pilot Project. Progress during the preceding two months was discussed, and proposals for the following months were put forth.

In Kgatleng District, the same function was carried out during the regular meetings of the District Extension Team (DET). It met monthly and discussed ESPP as one of its agenda items.

Both arrangements served the respective Districts well in monitoring the Pilot Project. However, both had serious shortcomings. In Southern District, it was difficult to get people to attend on a regular basis because they did not see it as their responsibility and they felt they were overburdened with other meetings. In Kgatleng District, the DET had many other agenda items to cover at each meeting and, therefore, was unable to spend much time discussing ESPP. The DET was very useful in monitoring progress but was incapable of giving the necessary time to planning. A major advantage to the DET was that the Pilot Project team was able to work within the Council and request assistance from other departments.

3.2 Tour of Previously Improved Villages

Recommendation

In order to better acquaint itself with the content of the programme, the District Sanitation Planning Committee should tour villages in a District which has been previously improved, as soon as possible after its first meeting.

Elaboration

The District Sanitation Coordinator should organize a tour of the previously improved villages (see map at front of book) as soon as possible after the first meeting of the District Sanitation Planning Committee. This tour should give Committee members an opportunity to gain first-hand experience of the problems, inputs and outputs of the ESPP Pilot Project.

Committee members should also have an opportunity to talk with the village Headman and, where possible, previous Village Sanita-

tion Coordinators and Village Sanitation Assistants. Their experience could help the Committee in its future deliberations and engender stronger programme spirit.

During the same tour, consideration should be given to visiting some or all of the villages under consideration for future improvement. It could prove helpful for the Committee to gain first-hand knowledge of these villages prior to preparing its District Sanitation Plan.

Pilot Project Experience

The Pilot Project team took visitors, and District and village staff on tours of the Pilot Project on many occasions. The team found that this led to increased interest in the Pilot Project on the part of those who were working in other villages. In other words, "seeing is believing."

3.3 Selection of Villages to Be Improved

Recommendation

If they have not already been identified in the Project Memorandum, the District Sanitation Planning Committee should select the clusters of villages which will be improved during the programme period. The major factors to be considered for this process are:

1. *Proximity*

The villages within a single cluster should be located relatively close to one another.

2. *Communal First Development Area*

If a Communal First Development Area has already been established in the District, the programme should commence within this area.

3. *Numbers*

It will be difficult either to administer more than five villages or to build more than 400 latrines within a single 18-month implementation period.

4. *Approvals*

The final selection must be approved by the District Council and, ultimately, the village residents.

Elaboration

Following the completion of its tour of previously improved villages, the District Sanitation Planning Committee can begin selecting the specific clusters of villages to be improved on an annual basis (see Figure 1). This will be a complex task, as a number of important factors come into play. The Committee may decide to prioritize these factors, recognizing that its selections represent one of the most important decisions in the programme.

The major factors which will need to be considered include the following:

1. *Proximity*

Villages within a single cluster, which are being improved within a single 18-month period, should be located in relatively close proximity to each other, in order:

- a) to improve staff efficiency;
- b) to reduce transportation costs;
- c) to facilitate centralized manufacturing and distribution of necessary building materials;

d) to accomplish common tasks in all the villages during restricted periods of implementation (e.g., building demonstration latrines during the short winter period).

In addition, one year's cluster of villages for one implementation period should be located near that for the next, as the schedules for each will overlap and both will need to share the same staff and transportation.

2. *Communal First Development Area*

If a Communal First Development Area has already been designated within the District, the Committee should seriously consider commencing its programme within this area in order to reinforce central government policies.

3. *Number of Villages/Number of Latrines*

Pilot Project experience demonstrated that it is difficult logistically either to administer more than five villages or to build more than 400 latrines within a single implementation cycle. In reviewing its options, the Committee will need to estimate the number of latrines it can anticipate being constructed in each of the

villages it is considering. In order to calculate the estimated number of latrines per village, take the number of plots in the village that are actually occupied (from the census) and subtract 10 per cent; half of the remainder can be expected to build latrines.

4. Final Approval

The Committee's recommendations regarding the location and number of villages to be improved will need to be forwarded to the District Council for final approval. Ultimately, the residents of each village will also have to support the programme if it is to be a success. Thus, a meeting of the Headman, the Village Development Committee and the Village

Extension Team should be called. At that meeting, these people should be told that their village is being considered for the programme, and the goals and potential benefits of the programme should be explained. If this group expresses an interest in continuing, a *Kgotla* meeting should be held during which the programme is explained and questions are answered. At this meeting, a decision should be taken by the village as to whether and how to proceed. This will help villagers feel it is their programme, as opposed to something from the outside which is being forced on them by Council.

Pilot Project Experience

In December of 1979, the District Development Officer, the District Land Officer, the Council Secretary and the District Project Officer of Southern and Kgatleng Districts held meetings in Kanye and Mochudi to select six villages in each District that were considered socially and geographically appropriate. The following are the sociological criteria which were used by this group to select the villages.

1. The villages should endorse the project, its goals and methods. This should be expressed at *Kgotla*. No village that is opposed to the project, or even lukewarm in its support, should be included, not even for experimental purposes.
2. The villages should represent different sizes and population densities.
3. The villages should represent different economic levels. Different rural occupations, such as animal husbandry and mixed subsistence farming, should be included and possibly also specialized activities and rural industries.

4. The villages should vary in distance from the District administration centres and the railway line. During any pilot or experimental phase, at least one remote village that suffers from lack of communication should be included.
5. The presence of village development structures and health facilities should vary.

The hydrogeological criteria, drawn up by Mr. H. Lann, the Head of Water Affairs, are included in Appendix I.

The final decision on which three villages, out of the six recommended by the Committee, should be included in the Pilot Project was left to the respective District Councils.

The three villages finally selected in Kgatleng District were Artesia, Mabalane and Olifants Drift. In Southern District they were Ranaka, Selokolela and Keng (for village summaries, see Appendix II).

One advantage in the final selection was that the chosen villages provided the Pilot Project team with the opportunity to experiment with a wide variety of soil types and

conditions. However, it soon became clear that the disadvantages outweighed the advantages. The overriding problem was that the selected villages were too far away from each other. A considerable amount of staff time was lost simply moving from one village to another. In turn, this was expensive and an excessive amount of petrol was used. The situation was further aggravated by the fact that the winter building season is short and, as a result, some work was delayed six months. In addition, it was impossible to deliver building materials to more than one village on a single trip. This led to a further

waste of petrol and increased inefficiency, particularly since the delivery trucks often carried only half a load.

The Pilot Project team made an attempt to supervise work and to hold meetings on delivery days in order to cut down on transportation costs, but this was not always possible. Quite simply, had the villages been located within a single cluster, that is, closer to each other, considerably more latrines could have been built for less money. Every effort must be made to ensure that the villages are closer to each other in this next stage.

3.4 District Sanitation Plan

Recommendation

A detailed District Sanitation Plan should be drawn up by the District Sanitation Planning Committee, under the direction of the District Sanitation Coordinator.

This plan should be based on an implementation period of 18 months for each separate cluster of villages.

Elaboration

Following the selection and approval of villages, the District Sanitation Planning Committee is in a position to draft a detailed implementation plan for the entire District (see Figure 1). This plan should identify separately the major components of District planning and include a rough time schedule for each. Next, the plan should identify the schedule for each village and each cluster of villages. The more detailed this plan is at the beginning, the easier it will be to administer and follow in the future. The District Sanitation Plan is important in three respects:

1. It encourages the Committee to get together to discuss the detailed objectives of the programme and how best to achieve these.
2. It establishes a sequence of events which will need to be adhered to if these objectives are to be accomplished within the available time and budget.
3. It serves as a benchmark against which the District Sanitation Coordinator can gauge and evaluate the programme's progress. For example, by comparing projected and actual progress, he should be able to anticipate and prepare for scheduling problems before they arise.

Typically, the majority of village residents may only reside in their home village during the dry winter season (June-November). Thus, because the programme relies not only on the establishment of close contact with these householders but also on their active participation in the construction process, a lot must be accomplished during the winter season. Traditionally, this is also the period when people build new houses or renovate old ones. In light of these factors, it is recommended that the District Sanitation Plan be based on

an 18-month period of implementation for each cluster of villages, so as to cover two winter construction seasons. In turn, work on each cluster would begin one year apart (see Figure 1).

Each 18-month cycle should be broken into three separate phases, as follows:

Phase I: *Motivation and Demonstration — June to November* (see Figure 3). This phase should commence with the calling of introductory *Kgotla* meetings in each of the villages in the first cluster. These should be followed by the selection of Village Sanitation Coordinators (VSCs) and Village Sanitation Assistants (VSAs). This phase culminates with the construction of demonstration latrines at selected sites in each village. Finally, a second *Kgotla* meeting should be called, just before people return to the lands, to look at the demonstration latrines and to explain the construction process, the overall costs for individuals and the methods of payment.

Phase II: *Preparation for Construction — December to May* (see Figure 4). During this phase, the construction teams in each village should be preparing for the coming winter. Slabs and ventpipes should be centrally manufactured and distributed to the villages for stockpiling, along with other local building materials. Village Headmen should be encouraged to commence the collection of payments from individual residents. A rule of thumb should be that 50

per cent of the total cost should be collected by the time construction begins in June. Contracts must be signed with each householder who wants to build a latrine.

Phase III: Construction — June to November
(see Figure 5).

During this phase, individual householders will undertake the

construction of their latrines, assisted by the VSAs. Also, the VSC should ensure that outstanding payments are collected before construction is completed.

Pilot Project Experience

The following Pilot Project experiences led to the recommendation of an 18-month, three-phase programme.

1. The Pilot Project team found that it took VSAs three to four months to complete the demonstration latrines. This construction could not begin before the VSAs had completed their own harvesting.
2. During the second year, the Pilot Project team attempted to get villagers to come back from the lands and start construction of the latrines before June. This met with total failure. It was not that the villagers were not interested but, rather, that they were busy with the harvest. Also, they knew that they would be back in their villages in a month or so and decided that they could start then.
3. The Pilot Project team found that many people who wanted to build latrines required time to accumulate enough money to pay for them.
4. The tendering and production supervision of the slabs and ventpipes took a great deal of time. Transportation of these materials to the villages was also very time-consuming.

5. The training and supervision of the VSC and VSAs had to be done carefully and, once again, took a great deal of time.
6. Many times, women wanted to sign a contract but could not do so until they had spoken with their husbands, who often were working away from the village and would not return for some months.
7. Informing the householders about the project required repeated contacts and took a great deal of the Pilot Project team's time.
8. The completion of the demonstration latrines generated a great deal of interest among the householders, and an increased number of contracts were signed.

Throughout the project, the Pilot Project team found a direct correlation between the amount of advance planning done and completion of ongoing activities.

3.5 Logistics

Recommendation

The District Sanitation Coordinator should familiarize himself with the logistical requirements of the programme as early as possible.

Elaboration

The District Sanitation Coordinator (DSC) should familiarize himself thoroughly with the Project Memorandum for his District Sanitation Programme as soon as possible. The Project Memorandum should describe the logistical supports (e.g., transportation, staff, revenue, etc.) which are required to implement the programme, and the DSC should arrange meetings with the District personnel concerned. It is essential to prepare for the implementation period as far ahead of time as possible. It is also essential to coordinate the activities of other Council departments in order to achieve the project goals on schedule.

It is especially important to meet with the *District Transport Officer* to ensure that the necessary vehicles (i.e., at least one five-ton lorry and one four-wheel-drive vehicle) are or will be available when they are required in the winter season.

The DSC should also contact the *Council Stores Officer*, as most programme materials will be bought through him using Local Purchase Orders. Remember that tendering processes are long and should begin immediately. The DSC should attempt to familiarize the Council Stores Officer with the kinds of demands that the sanitation programme will place upon him.

Next, it is important to meet with the *District Work Supervisor*. He may eventually need to hire or lend one or two builders to serve as Village Sanitation Foremen and should be made aware of this. The implementation of the programme may also require the services of additional casual labourers from time to time from the Work Supervisor's department.

The DSC should also contact the *Revenue Officer* in order to review Council revenue policies. Money reverting to the Council from the sale of latrine materials in the villages will be passing through his department. It will also be necessary to discuss and decide on methods of payment and revenue collection at the village level.

Finally, the DSC needs to advise the Council's *Senior Community Development Officer* to contact all Assistant Community Development Officers in the villages to request their assistance in explaining and implementing the programme. Similarly, the *Senior Nursing Sister* will need to advise the village Family Welfare Educators.

Pilot Project Experience

Pilot Project experience emphasizes the need to make arrangements for all project activities well in advance. The Local Purchase Order system is time-consuming, as several signatures are required. Transport must be available for delivery of goods. Purchasing early will ensure that the programme is not delayed due to late arrival of materials. The tendering system is long because tenders must be

advertised for a period of a month. The schedules of Council officers often fill up early as well. Talk to them well ahead of time so that the programme's activities will occur on schedule.

Pilot Project experience indicates that everything takes more time than is estimated.

3.6 Dissemination of Information

Recommendation

Village residents and members of the project team should be kept fully informed of the progress and content of the programme at all times.

Elaboration

The importance of thorough and accurate dissemination of information during the implementation period cannot be overemphasized. This means informing not only the village residents but also the project staff, who will be passing on what they know to the public.

The two most important forms of communication are as follows:

1. *The Kgotla Meeting*

The *Kgotla* is the traditional focus of information exchange and public communications. Information distributed here will gain added legitimacy because it is supported by the Chief or Headman, who, in turn, feels more a part of the programme.

A recent problem with the *Kgotla* is that meetings have tended to attract fewer and fewer people. Four things can be done to improve attendance at the meetings where sanitation is discussed:

- a) The sanitation programme can be integrated with those of other organizations, such as the Land Board.
- b) The meeting can be advertised a week in advance by sending written handouts (see Appendix III) home with schoolchildren. These handouts should detail the time, place and content of the meeting and

should be distributed on a Friday so that those householders working or living at the lands might receive word over the weekend from their visiting children.

- c) The meeting can be announced by loudspeaker on the day it is to take place and drop more handouts as you travel through the village.
- d) The meetings can be made more lively by using slides, film, theatre, etc.

2. *House Calls*

In some villages, attendance at *Kgotla* meetings may be low. Consequently, it is essential that the Village Sanitation Coordinator (VSC) follow up the meetings with individual house calls to all occupied plots in the village. This will ensure that everyone receives the correct information. During the call, the VSC should outline the entire programme, focusing on its major components, costs to the plot-holder, the plot-holder's input and District Council's role in the implementation. It should also be possible for householders to sign a contract (see Appendix VI) at this point if they want to. Finally, the VSC should leave another copy of the handout with each householder to ensure that he/she has a copy to refer to.

Pilot Project Experience

The distribution of accurate information was one of the most perplexing problems encountered by the Pilot Project team. Most major problems resulted from misinformation or a total lack of information.

It cannot be emphasized strongly enough how important this aspect of the project is. If it is done carefully and thoroughly, the

programme should proceed with fewer problems.

Three different approaches were employed. The *Kgotla*, the traditional method of disseminating information, was used first. Attendance was fair to good in most villages. However, in Ranaka, where attendance was better than elsewhere, it still only amounted to about 7

per cent of the total village population. Since it was realized that this was not enough, efforts were then directed at ways of improving attendance at the meetings. The Pilot Project team drove through the village and announced the upcoming meeting over loudspeakers. This met with some success, but the cost of the equipment was considered beyond the means of most villages. However, if the District already has the equipment, then it should be used. The major problem with a public-address system is that it is only good for people in the village. Those at the lands cannot hear it.

Another method used to enhance *Kgotla* attendance was the distribution of *written notices* to schoolchildren one week before the meeting. The results of this were very good and boosted attendance by more than 100 per cent. However, it required much advance planning and an additional trip to the village. When this advance notice included basic information about the project, it served two purposes and therefore was much more effective.

Towards the end of the Pilot Project, the VSCs were sent out to visit houses door-to-door in order to explain the contracts and the building procedure. This proved to be most effective. The situation that best illustrates this happened in Ranaka. During a well-attended *Kgotla* meeting, organized to explain the contract and encourage people to sign up, villagers were told that they should visit the Revenue Officer as soon as possible to sign contracts. After one week, only 11 contracts had been signed. The VSC, VSAs and the District Sanitation Foreman then visited every house and explained the procedures and offered to sign contracts. In the next three days, 104 more contracts were signed. Door-to-door visits are, by far, the best way to inform the villagers. While they are time-consuming and costly, the Pilot Project team members felt that the time and cost were well worth it.

3.7 Other Agencies

Recommendation

The program should make use of the expertise available in other government ministries and agencies concerned with sanitation.

Elaboration

There are several tasks that need to be performed as part of the sanitation programme that require special skills or equipment not possessed in the District. For example, an analysis of subsurface geology in programme villages is necessary prior to selecting the final substructure design. This should be done by the Department of Geological Surveys. Water tables must also be located by the Department of Water Affairs (DWA). Borehole water may need to be

monitored. Construction booklets need to be reproduced. Currently, this kind of expertise does not exist at the District level. There are, however, departments of government that do this work routinely and that make their personnel available to do such work for Councils. These departments should be requested to help when needed.

Pilot Project Experience

The Pilot Project was designed in such a way that the two Districts would work closely with the Department of Non-Formal Education in the Ministry of Education, the Ministry of Local Government and Lands (MLGL), and the DWA. The Department of Non-Formal Education was ultimately responsible for the

written materials produced for the Pilot Project by the Project Materials Producer. The MLGL administered the Pilot Project in liaison with the Districts. The DWA carried out all of the water testing. Without these inputs, the Pilot Project could not have succeeded.

4.0 The Programme Team

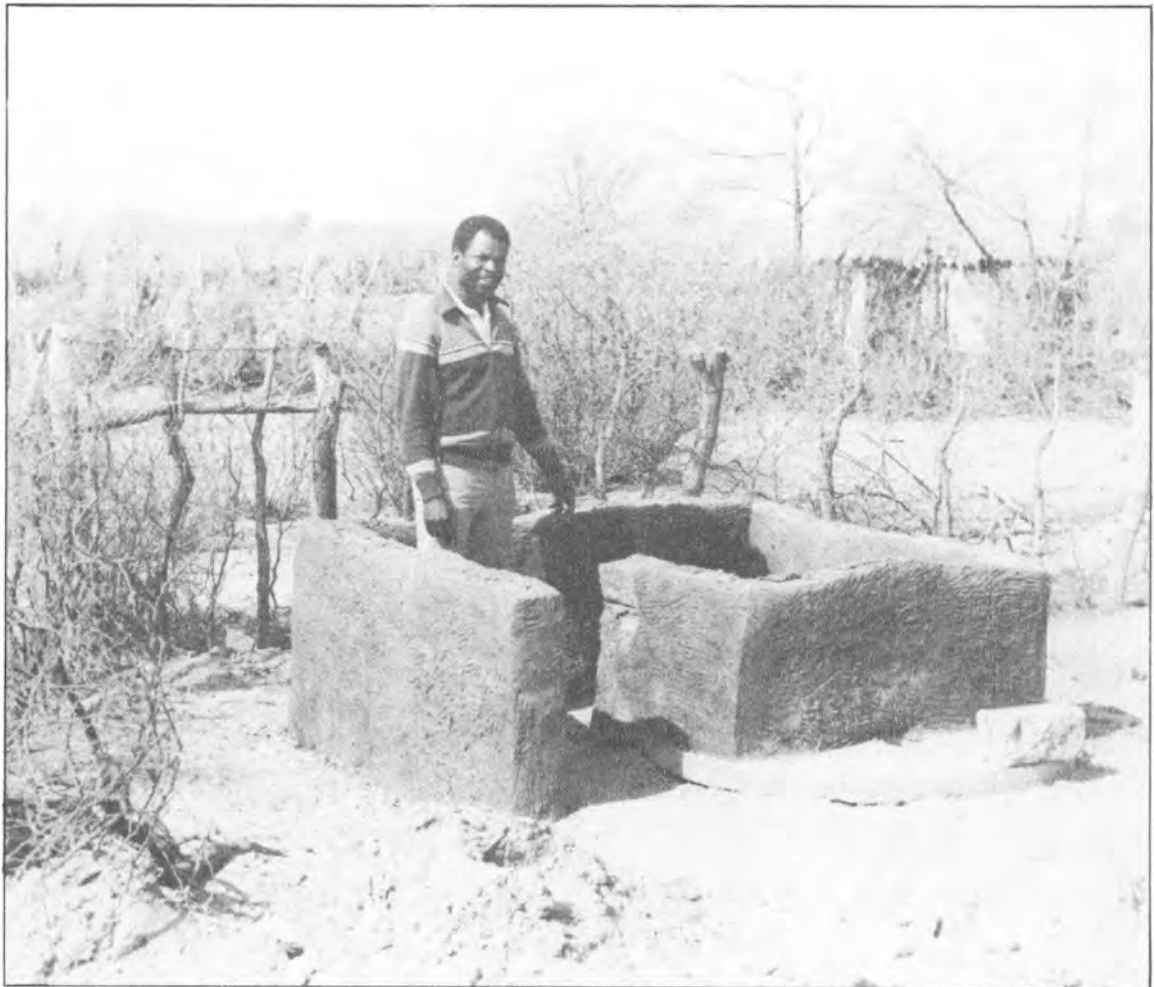

4.1 Senior Public Health Engineer

Recommendation

The Ministry of Local Government and Lands should appoint the office of the Senior Public Health Engineer to oversee the design and implementation of District Sanitation Programmes throughout Botswana.

Elaboration

The office of the Senior Public Health Engineer (SPHE) is obviously the key agency effecting the National Rural Sanitation Programme. The office of the SPHE should:

1. advise District Sanitation Coordinators (DSCs) on all aspects of programme planning and implementation;
2. work in close liaison with Senior Water Officers or Senior Works Foremen and the DSC in setting up and administering ongoing sanitation training programmes;
3. initiate and investigate requests for additional donor funding relating to sanitation and rural environmental improvement;
4. promote the National Rural Sanitation Programme by addressing District and Local Councils when requested;
5. review all technical aspects of the District Sanitation Programmes;
6. approve all latrine designs selected for specific villages;
7. initiate monitoring and evaluation programmes for completed components of the District Sanitation Programme.

Pilot Project Experience

The Pilot Project was coordinated by a team funded by the United States Agency for International Development. During the later stages of the Pilot Project, a national counterpart was assigned to the SPHE, and he coordinated the first National Rural Sanitation Programme.

4.2 District Sanitation Coordinator

Recommendation

A full-time District Sanitation Coordinator should be appointed in each District undertaking a sanitation programme, and he should remain in the post until the end of the programme.

Elaboration

The District Sanitation Coordinator (DSC) should:

1. serve as Secretary of the District Sanitation Planning Committee;
2. work with the Senior Public Health Engineer to plan, organize and implement training programmes for project staff at the District and village level (see Appendices XVI and XVII);
3. report regularly to the District Extension Team, the District Officer and the Senior Public Health Engineer on implementation progress;
4. supervise the District Sanitation Foreman in the construction phases of the programme;
5. supervise the procurement of construction tools and materials;
6. ensure that proper stores procedures are followed at both Council and village levels;
7. supervise payment of village-based staff;
8. complete regular end-of-month progress reports for the Senior Public Health Engineer;
9. keep a day-to-day diary and ensure that all project staff do the same;
10. work with the District Sanitation Foreman and Village Sanitation Coordinators in preparing their weekly or biweekly work plans;
11. coordinate ongoing monitoring of the programme.

It is clear from the Pilot Project experience that the DSC must be appointed on a full-time basis, and should, if at all possible, remain in the post over the entire period of implementation of the District programme.

Pilot Project Experience

The original ESPP Project Paper called for Kgatleng and Southern Districts to each provide a District Officer (DO) to work half-time with the Pilot Project team. Southern District appointed the DO, and Kgatleng, the Senior Community Development Officer (SCDO). In both cases, they already had heavy work loads and, thus, were faced with competing responsibilities, not all of which could be achieved. Subsequently, both the SCDO and DO were assigned to the National

Census and were lost to the Pilot Project for four critical months in the winter building season. Finally, the SCDO was transferred altogether and not replaced. Some attempt was made to replace the DO with another Council staff member but he was equally busy. In summary then, the Pilot Project team never really had the assistance of a District Sanitation Coordinator and, thus, came to realize his importance.

4.3 District Sanitation Foreman

Recommendation

A District Sanitation Foreman should be hired on a full-time basis to coordinate and supervise the construction of all the latrines in each cluster of villages.

Elaboration

Reporting to the District Sanitation Coordinator (DSC), the District Sanitation Foreman (DSF) should:

1. coordinate and supervise all latrine construction activities at the village level, including both demonstration and household latrines;
2. be responsible for organizing transportation of materials to the villages;
3. work closely with the Village Sanitation Coordinator (VSC) in the preparation of construction schedules, weekly work plans and village payment sheets for the Village Sanitation Assistants (VSAs);
4. supervise the VSAs;

5. liaise with the VSC in setting up the village storeroom and stores procedures;
6. instruct the VSAs in techniques of latrine construction;
7. keep a daily journal.

It should be noted that one DSF should be assigned to *each* cluster of villages (not more than five villages in one cluster). When the implementation of the programme in one village overlaps with that of another, a single foreman will *not* be able to train the VSAs in one cluster of villages at the same time that he is supervising the construction of household latrines in another.

Pilot Project Experience

Both District Sanitation Foremen were trained during the building of the demonstration latrines for the Kgatleng District Agricultural Show in July 1981. Soon after that, they began supervision of construction activities in their respective Districts and conducted further training of VSAs. They were indispensable to the Pilot Project.

They both did their own planning on a weekly basis, using a form supplied by the Pilot Project (see Appendix VII — Planning and Report Form) but disliked doing so. They

said that each day's activities were dependent on the preceding day's progress and that a plan was, therefore, difficult to write. While this may be true, it does not eliminate the need for a weekly plan, even if it needs to be altered. DSFs should draw up such a plan, in consultation with the DSC, on a weekly basis. The plan should keep activities on schedule and economize on transport costs, which can become excessive if trips to and from the programme area are not rationalized.

4.4 Village Sanitation Coordinator

Recommendation

A village resident should be selected to serve as the Village Sanitation Coordinator in each village.

Elaboration

The post of Village Sanitation Coordinator (VSC) is a key one. The VSC should be selected by the District Sanitation Coordinator (DSC) with considerable care. The DSC should consult with the village Headman in this selection.

The VSC should have the following qualifications:

- a) be at least 20 years old;
- b) have at least junior college education (Cambridge exams, if possible);
- c) be a resident of the village he/she will be working in;
- d) be literate in Setswana and English;
- e) have a knowledge of basic mathematics;
- f) be recommended by the Headman.

The VSC shall report to the DSC and should:

1. visit all householders in the village to explain the programme, the need for latrines, the method of construction, and the contract;
2. keep a daily record of what each Village Sanitation Assistant (VSA) does

and complete payment sheets at the end of each month;

3. be responsible for village stores and keep an inventory of tools and materials (signing in materials delivered by Council, and signing out tools and materials taken by VSAs);
4. work closely with the village Headman and the Village Extension Team;
5. organize *Kgotla* meetings;
6. work closely with the Family Welfare Educator and the Revenue Officer in the collection of materials payments;
7. keep a daily diary which should include problems encountered, questions, materials and tools needed, etc.;
8. coordinate the Village Baseline Survey;
9. maintain a physical progress record on household latrines (see Appendix VIII — Village Latrine Inventory),

Pilot Project Experience

The position of Village Sanitation Coordinator (VSC) was a late addition to the Pilot Project. It was first thought that the organizational work in the village could be done by the Assistant Community Development Officer (ACDO) or the Family Welfare Educator (FWE). However, this turned out not to be the case. During the duration of the project, the ACDOs assigned to five of the six Pilot Project

villages were transferred (only the one in Keng remained), and only two of the original FWEs remained (in Ranaka and Keng).

Lack of motivation is also a problem. Several recent studies have shown that many villagers have never seen their ACDO. One ACDO in a Pilot Project village told the Pilot Project team that he

believed that if he did nothing he would soon be transferred to a better place, as he was unhappy in his present post. Some also had a very heavy work load (i.e., FWEs in Ranaka and Keng). Some were also stationed in other villages and had no transport to project villages (ACDOs in Ranaka, Selokolela, Keng, Mabalane).

For these reasons, the VSCs were hired and turned out to be very effective. They

were responsible for housecalls to explain the project, for signing contracts, for encouraging payment, and for coordinating the Councils' component of latrine construction. They were also responsible for coordinating the VSAs' schedules, recording their working hours, and relaying problems to Council project staff.

4.5 Village Sanitation Assistants

Recommendation

At least two village residents should be selected by the Headman and the Village Development Committee to serve as Village Sanitation Assistants.

Elaboration

On average, two Village Sanitation Assistants (VSAs) will be required in each village. Preferably, one should be male and one female to ensure that, together, they have experience in the full range of modern (male) and traditional (female) building techniques. For example, while a man may not make mud bricks, a woman may not dig a pit. The VSAs should be selected by the village Headman and/or the Village Development Committee, and should have the following qualifications:

- a) be old enough to have participated in the construction of their own house;
- b) be residents of the village where they are to be employed;
- c) have a reputation for honesty and hard work;
- d) preferably, have some history of salaried employment;
- e) preferably, be literate and/or numerate.

The VSAs shall report to the Village Sanitation Coordinator (VSC) and will:

1. build demonstration latrines as part of their training;
2. construct components of householders' latrines as required (see Section 6.6);
3. work closely with the VSC in informing villagers and encouraging villager participation.

Pilot Project Experience

VSAs were selected by Headmen, often in conjunction with the Village Development Committee. This worked satisfactorily and, in most cases, produced adequate Pilot Project village staff. The important characteristics of a good VSA can be outlined as follows:

Age: VSAs ranged in age from 23 to more than 60. Two younger assistants who were chosen in Olifants Drift were ultimately rejected. Neither had any experience building with either traditional or modern materials. The 60-year-old female VSA performed her work very well. However, she was not required to do any heavy concrete work.

Sex: Of the 12 VSAs, nine were male and three were female. There was no appreciable difference in work performance between male and female VSAs. The female VSAs in

Ranaka and Selokolela often spoke in favour of the project at *Kgotla* meetings and explained things that were unclear. Males usually did not speak. The female VSA in Ranaka often did motivational work on her own without being asked.

Literacy: A few of the VSAs were literate and thus helpful when contracts were being signed. They were also able to interpret the substructure manuals which were produced.

Previous Work Experience: Those VSAs with a previous history of salaried employment worked more quickly and efficiently than the others. All had previous experience with traditional building, and all worked in this area satisfactorily. Some had previous experience with concrete construction but still had difficulty producing slabs that did not crack.

Strength: Most of the work required by the programme is not heavy. There is, however, some loading of sand and earth into a truck, loading and off-loading of concrete slabs and packets of cement, and operating a jack-hammer. When one VSA was unable to do this work, it was done by another, by Council labour or by a labourer hired on the spot.

4.6 Village Development Committee/ Village Extension Team

Recommendation

Where possible, the Village Development Committee and the Village Extension Team should be encouraged to become actively involved in the Village Sanitation Programme.

A special effort should be made to gain the assistance of the Family Welfare Educator in promoting the educational components of the programme.

Elaboration

In many villages in Botswana, the Village Development Committee (VDC) and the Village Extension Team (VET) are very active, village-based organizations. If approached in the proper way, they can be of great help to the programme.

The VDC is chosen by the *Kgotla* every two years and is responsible to the *Kgotla*. Its major task is identifying and organizing village development projects. The village Headman is a key member because he has the authority and power to mobilize the villagers. The VDC might best be used as a consultative committee in setting up programme activities in the village, and the initial contact in the village should be made through it. A word of warning — if an effort is not made to work with the VDC during the initial phases of the programme, the programme could suffer a serious loss of support and its progress could be impeded.

The VET is made up of the village-level extension staff. It will normally consist of the Assistant Community Development Officer (Secretary), the Agricultural Demonstrator, the Staff Nurse, the Family Welfare Educator and the Head Teacher. These extension workers are in daily contact with the people and, in most cases, are well known by them. Therefore, it is advisable to keep these people well informed and to encourage them to play an active role in informing all those householders they come in contact with about the programme. It might be advisable to ask the VET if the Village Sanitation Coordinator (VSC) could sit in on VET meetings during the programme's duration in the village. This would have two advantages: first, the VSC

could provide the link between the programme and the VET; and, second, the sanitation programme would be linked to other village activities.

The Family Welfare Educator (FWE) is the village health educator. This person is charged with the job of encouraging better health practices. The FWE does this by making house visits, talking to people at the health post or clinics, and giving monthly talks at the *Kgotla* and clinics. One of the subject areas covered is environmental sanitation. Recent studies have shown the FWE to be one of the most effective and best known of the village extension staff. Therefore, the involvement of the FWE in the programme could be very beneficial. However, the FWE will probably be very busy already, and any additional demand on her time could be met by stiff opposition. It will, therefore, be necessary to approach the FWE carefully by suggesting that she might help inform the villagers about the programme during her present house visits and other contacts. The FWE could also be asked to hand out written material. (A series of educational materials were produced during the ESPP Pilot Project. These materials can be obtained from the Senior Public Health Engineer in the Ministry of Local Government and Lands.)

Pilot Project Experience

In the first year of the ESPP Pilot Project, a great effort was made to involve the VDC in the development of the project. If no VDC existed, then a Village Sanitation Committee was created. The Pilot Project team found it difficult to organize meetings with either of these groups. When dates and times were set, only a few members would show up. On the other hand, when well attended, these meetings proved quite effective, and useful suggestions were forthcoming.

After the first year, the Pilot Project team adopted the VDC as strictly a consultative body. In other words, meetings were only called when there was a change in direction or a new component of the project to discuss. In a number of villages, meetings with the VDC

were very poorly attended and changes were cleared with the Headman instead.

Liaison with the VET was severely hampered by the transfer of its members to other parts of the country. In addition, the Pilot Project team discovered that the Assistant Community Development Officers generally failed to call any meetings with village residents. In part, these persons were supposed to attend to several villages at one time and were usually without transportation. Generally speaking, extension workers were encountered on a one-to-one basis and would lend a hand, depending on their work load and degree of interest.

5.0 Latrine Design and Construction



5.1 Latrine Design

Recommendation

The design of latrines used in the District Sanitation Programme should:

1. eliminate offensive odours;
2. control the movement of flies and other insects to and from the pit;
3. provide for latrines which are safe to use and perceived as such by the users;
4. be affordable to village residents;
5. be attractive, hygienic and easily maintained.

Elaboration

Although most people in rural areas would like to have a latrine for health, privacy, convenience, status or other reasons, very few have actually built them. When asked why, a number of reasons are given: they smell bad and are unpleasant to enter; they may collapse with someone inside; children may fall through the hole into the pit; they attract flies to the household; or they are too expensive. All of these objections can be overcome if the

latrine is properly designed and if appropriate methods of construction are used (see Section 5.2 — Latrine Construction). The advantages of having a latrine are numerous, and when it is properly designed, most people will choose to build one. Currently, four BOTVIP designs have been approved for use in rural areas (see Figures 14-17).

Pilot Project Experience

The first task of the Pilot Project was to design a latrine that would overcome people's objections to them. Some of the observations and procedures used were as follows:

Odour: Excreta in a latrine pit undergoes natural decomposition by micro-organisms. Decomposition is good because it reduces the volume of the waste so the latrine lasts longer, and also because it destroys the germs that cause disease. However, this decomposition produces unpleasant-smelling gases. If these gases rise up into the latrine superstructure, they make entering the latrine unpleasant. To avoid this, the design must ensure that these gases are vented to the outside of the superstructure. The ventpipe will do this if (1) it is at least 150 mm in diameter; (2) it is taller than the latrine so that wind blowing over the top pulls odours out; and (3) it is positioned in such a way that the sun heats the air inside so that it rises and is vented. The latter can be accomplished by positioning the ventpipe on

the sunnier north side of the latrine and using a dark-coloured pipe to absorb as much heat as possible.

Flies: Flies lay their eggs in human excreta. They are attracted by the smell of the excreta, whether it is on the ground or in a latrine pit. Flies mature in the excreta and then leave it, carrying with them disease germs that are often then carried to people's food. If nothing is done to prevent the exit of flies from the latrine pit, the number of flies in the area of the household will increase and cause a greater health hazard.

It is almost impossible to prevent some flies from entering a latrine pit, and even one fly lays millions of eggs. It is possible, however, to prevent most of these flies from escaping from the pit. There are two ways to do this. First, a barrier can be erected between the pit and the exterior. Use of physical barriers requires that all entrances to the pit be blocked. These include the hole for the

ventpipe, which must be blocked by a screen. The seat can be blocked with a cover or screen but must be regularly unblocked when it is in use.

The alternative approach is to provide a preferred exit for the flies, and then to screen it. Flies in a dark place will only fly toward light. Thus, the Pilot Project latrines were designed so that the only light seen by flies inside the pit came down the ventpipe. The flies would thus attempt to exit the pit through the ventpipe and would be blocked by the screen secured to its top end. It is important to ensure that the inside of the latrine is kept dark so that light entering the pit through the seat will not attract the flies to exit there. The small internal wall in both superstructure types is designed for this purpose.

Physical Safety: There are many stories of latrines that have collapsed into their pits while the owner was inside. There are also widespread fears that small children will fall through seat holes and be trapped in the pit. In order to alleviate these fears, latrines must be designed which are stable. They should have a seat hole which is small enough that no one will be afraid that children may fall through.

Stability is accomplished in three ways. *First*, the superstructure is offset from the pit. Thus, most of the weight of the superstructure

rests on undisturbed ground rather than on the slab over the pit (see Figure 14). *Second*, the slabs across the pit are extended well beyond the edge of the pit so that they also rest on undisturbed ground; the pit has also been narrowed from the original design to reduce the possibility of the slabs breaking. *Third*, the pit is strengthened against collapse. In stable soils, this means placing a concrete ringbeam around the top of the pit to prevent rain water from eroding the edge. In unstable soils, the pits are lined from top to bottom. In the Pilot Project, this was done in two ways: with the wire-mesh and filter-fabric lining, and with a trapezoidal brick lining (see Appendices IX-XI for descriptions of these methods).

The seat insert was designed so that the top was large enough to be comfortable for adult use, but tapered to a small hole at the bottom, so as to alleviate fears of children falling through.

The Pilot Project team experimented with a wide variety of different designs for substructures and superstructures before selecting the combination of two substructures and three superstructures that were actually built within the six Pilot Project villages. These are called BOTVIPs, and can be combined to create a number of different designs (see Figures 14-17).

5.2 Latrine Construction

Recommendation

The construction techniques and materials used in building the District Sanitation Programme latrines should be chosen to minimize the householder's costs and to maximize the degree to which the householder can participate in the construction process.

Elaboration

The main reason that most people in rural areas do not have latrines is because they cannot afford them. Those which do exist may have cost anywhere from P250 to P600 to build, that is, more than most families' annual income. Consequently, it is critical that construction costs be kept as low as possible without sacrificing quality.

There are two ways of reducing costs: *first*, encourage self-help construction; and, *second*, make greater use of building materials available locally. In fact, the two are closely related. For example, the reason many existing latrines

cost so much is that the householder had to hire someone else to build his latrine because he thought that it had to be built of concrete block, a material which was unfamiliar. Thus, the contractor needed specialized skills and, in addition, cement had to be brought to the village from outside, both of which added to the costs. In contrast, materials which are available locally are often suitable for latrine construction; they will be familiar to village residents and it is likely that the villagers already know how to work with them.

Pilot Project Experience

Once the latrine was designed, the method used to construct it was simplified. The best method for building each of the latrine components was found on a trial-and-error basis. The following is a description of Pilot Project experience, focusing on each component of the design.

Latrine Pits: The most difficult and important decision to be made in constructing a latrine pit is whether or not the soil around the pit is strong enough to support the weight of a superstructure without some kind of reinforcing. In the villages, soils vary widely over a very small distance. In Selokolela, for example, the subsurface soils change from alluvial sand and cobbles to brown sand-clay to red sand to very hard sandstone over a distance of only 500 metres. In addition, different soil types may be found at different levels in the pit, and soil evaluations also may not yield entirely useful information. All soil analyses done in Ranaka and Selokolela indicated that latrine pits should be lined. However, when existing latrines were surveyed, it was found that only half had lined pits and that no one could remember a latrine collapsing. Southern

District Council does not line the latrines it builds in these villages. The Pilot Project did not line pits in Mabalane, Artesia, Olifants Drift or most of Ranaka, and none of the pits have collapsed.

The problem has been simplified somewhat by the development of low-cost methods of pit lining by the Pilot Project. With the availability of these linings and the unknown quality of most soils, the Pilot Project would recommend that all pits be lined except those in rock. The latter should be dug using a jackhammer (see Appendix XIII) or be partially elevated.

Ringbeam: A concrete ringbeam was constructed around the top of each pit to prevent inflow of rainwater (see Appendix IX). Even good soil is susceptible to erosion if water runs over an exposed edge. On the first demonstration latrines, the pit was dug first and the concrete ringbeam was placed around the top, using wood or corrugated-metal shutters. However, it was found that these pits were often dug too wide for the standard slabs and also that considerable labour was

required to place the shutters and pour the concrete. The Pilot Project discovered that if the ringbeam was built first, both of these problems could be solved. The ringbeam then served as a guide to those digging the pit. It also eliminated the need to use shutters. A ringbeam has also been used with the wire-mesh and filter-fabric lining (see Appendix X and Figures 15 and 17). This is essentially for support of the slab.

Latrine Pit Lining: Soils in Keng were structurally unstable, so some type of lining was required. The common open-jointed, cement-block type was ruled out because of the cost of material and labour. It was suggested that a lining be formed by stacking two or three 200-litre drums, without their ends, in the pit and backfilling around them. This was done with the loose sand in Keng and worked very well. However, the cost of drums proved prohibitive and this practice was discontinued.

Another method tried at Keng involved bending welded reinforcing mesh in a circle and covering it with fibreglass flyscreen. However, it was found that the sand was so fine it passed through the flyscreen. The flyscreen was then replaced with a filter fabric, and the combination proved to be strong and capable of holding back even the smallest sand particle. It is felt that the steel may rust or corrode below the level of the waste over a period of years and that a pit with this lining is probably not pumpable, although further tests are required (see Appendix X and Figures 15 and 17).

A lining of curved interlocking blocks was also installed in Keng. A straight block that interlocks with those above and below is available from Ngami Construction in Jwaneng. This concept was modified by Rural Industries Innovation Centre in Kanye to curvilinear blocks which, when placed end to end, formed a circle of one square metre area, or the same as the rectangular pit (see Figure

7). These blocks were made by a block yard in Kanye on special order. The pit lined with them in Keng (at the home of the Headman) was quite successful. However, costs and logistics were excessive. The bricks cost P32 per metre of pit lining. It is a fairly complex block and requires a skilled block-making crew to make it. A five-ton truck can carry only enough blocks for one latrine, so transport is also expensive.

This block was then modified to a straight trapezoidal brick that could be made in the village with a low cement/sand ratio (see Figure 8). These bricks, when placed end to end, also form a circle (see Figure 10). They can be made in the village in the same way that mud bricks are made. Two householders in Keng have borrowed the project mould and have each made hundreds of bricks with minimal instruction and no supervision. Two pits have been lined with the bricks to a depth of 2.5 and 6 metres. Permeability and crushing-strength tests performed at the Botswana Polytechnic show the bricks to be of adequate strength. One packet of cement will make 50 of these bricks and 55 of the modified brick produced later. At P3.60 per packet of cement, this lining will cost P5.60 per metre with the original brick (exclusive of labour) and P4.90 per metre with the modified brick (reduced thickness and reduced radius, exclusive of labour). Two men can line a 2.5-metre pit with these bricks in about three hours (see Figures 15 and 17).

Slabs: Initially, serious consideration was given to using wooden poles to cover the pit in order to reduce costs. This was not done for several reasons. First, large numbers of straight poles are difficult to find. Second, *Kgotla* meetings expressed reservations about their safety. Third, wood in the ground is rapidly attacked by ants and termites. Several suggestions were made to alleviate some of these problems. Some thought motor oil painted on the poles would keep insects away.

Others suggested that the ash of certain aloe trees covering the poles would protect them from insects, as the same ash is traditionally mixed with grain for protection. Another possibility considered was a treatment with a bitumen. The owner of Timber Treatment in Gaborone, however, advised that this would have to be done under conditions of heat and pressure. Lack of previous experience led the Pilot Project to focus its attention on the use of concrete slabs.

Concrete slabs were designed to extend 60 cm beyond the edge of the narrow pit to distribute the load above the pit as widely as possible. This minimized the risk of collapse of uncertain soils under the weight of a latrine superstructure but increased the cost, the weight of the slabs, and the quantities of cement required. Three slabs were used instead of one. Even so, the slabs were quite heavy and four people were required to move one over a distance. A light-weight, fibreglass-reinforced slab was tested but proved much more expensive, and was abandoned because of excessive deflection. A circular slab was designed to cover the round pits (see Figure 12).

The original plan for slab construction was to require each householder to build his/her own slabs — with moulds, materials and advice being supplied by Councils. Village Sanitation Assistants (VSAs) in all villages except Keng were trained to build slabs for the demonstration latrines. However, the quality of many of these was poor. Sometimes not enough cement was used. Sometimes too much water was used. One batch of sand used was found to have a very high portion of fines. Given that adequate supervision of ten VSAs was difficult, it was decided that supervision of slab making in hundreds of households was virtually impossible. (Even one large batch of slabs at Kanye Brigades construction yard had to be rejected because

adequate supervision had not been provided to ensure good quality.)

Tenders for slabs built by one organization will help ensure good-quality slabs. Even so, supervision should be provided on a daily basis.

Walls: The techniques for building walls and roofs with local materials are well known by most people in rural areas. While contemporary *lohwapas* (households) contain both modern and traditional house types, the traditional types are more popular. These are solid, and ideally suited to climatic conditions.

Moreover, except for the shape of the walls, it is not necessary to train the householder to construct a latrine using these traditional techniques. Pit latrines can be maintained with an annual application of a mud-dung mixture in the same way that the houses are.

The wall configurations used were the double-radius snail shape (see Figures 15 and 17) developed by the Ministry of Health in Zimbabwe, and a comparable rectilinear version (see Figures 14 and 16) suggested by local village groups. The two shapes are ideal for keeping the seat area darkened, as both have small interior walls which block the light.

Demonstration latrines were built without doors to show that the user could attain privacy in the latrine without having to purchase a door. Many householders in the Pilot Project villages chose to add a door, using materials they had available. Demonstration latrines should continue to be built without doors, as the programme will not be providing doors. People who decide they want doors should plan for them before commencing construction.

The walls on the double-radius model were marked using the traditional cord and stick method. A centre was selected, and a stick on the end of a cord was used to trace a circle on the ground. Two different centres, each with a

measured cord, were used to mark the two semicircles of the walls. Using this method proved difficult in standardizing the size of the walls and door. Fibreglass patterns for both round- and square-wall configurations were then developed (see Figure 13). Bricks were placed around the edge of the pattern. This proved much more satisfactory. The VSAs took the patterns to the home of the builder and asked if a round or square latrine was desired. Once the shape was selected, the VSA marked the walls, using the appropriate pattern.

Initially, the VSAs merely marked out the walls by tracing around the pattern with a stick. However, it was discovered that if the householder did not begin his/her walls immediately, these marks disappeared and the VSA would have to return and replace them. It was also discovered that some householders were not sure how to begin their walls because of the difference in height between the slabs and grade. Subsequently, VSAs began placing the first two or three courses of bricks in the traditional fashion, beginning with the first course below the ground surface. Bricks for this were provided by the householder, who then was required to complete the walls and roof.

Roof: All roofs on the demonstration latrines were thatched professionally because they were in public places where maintenance was unlikely. The Pilot Project had hoped that most householders would use traditional thatch. In fact, however, most householders chose to use corrugated-iron roofs on their own latrines. This was due partially to a recent drought, which meant that adequate roofing grass was unavailable. Also, many people had a sheet or so of used corrugated roofing available and found it easier to install, more permanent, and less expensive. In either case, householders easily built their own roofs.

Ventpipes: Except in Keng, demonstration latrines were built with 150-mm pvc pipe, painted black, because the lower-cost cement-wash hessian ventpipes were not available at the time the prototypes were being built. The Keng latrines used the hessian pipes. The large ventpipe was used at the recommendation of a World Bank study on ventilation that was conducted in Botswana concurrently with the Pilot Project. Both the pvc and cement-wash hessian (see Appendix XII) ventpipes proved adequate in ventilation. The hessian pipe was definitely cost-effective (P6, as opposed to P22 for the pvc pipe), but some difficulties were experienced in procurement of materials. More training and organization are needed if the hessian ventpipe is used. The Pilot Project also considered the possibility of using a plastered mud-brick ventpipe. It was felt that, as it could not be plastered on the inside, it would soon be washed away by rain.

Seats: Experience throughout Botswana has shown that most people prefer to use an actual seat as opposed to a squat plate. This was also the preference expressed in most *Kgotla* meetings in Pilot Project villages. The demonstration latrines were therefore all built with seats. The seats were built by placing a small concrete slab on a plastered mud-brick pedestal. The concrete slab had a small 200-mm hole in it so that it would be safe for use by children. Adults, however, complained that this hole was too small for them to use comfortably. The rough interior was also difficult to clean.

At the recommendation of an evaluation report, a fibreglass seat insert was designed for use in the latrine. This was designed to be large enough at the top (300 mm) to be comfortable for use by adults and small enough where it tapers to pass through the slab (150 mm) at the base that parents would not worry about children falling through it. It

is also easily cleaned. The lower opening has since been enlarged to 200 mm diameter.

The VSAs have been trained to install these inserts at people's homes and are paid to do so. A frame is built of mud bricks the size of

the fibreglass insert and mud mortar is placed over the frame. The insert is then pressed into the mud so that the base of the insert passes through the hole in the slab.

6.0 Village Implementation



6.1 Meetings and Handouts

Recommendation

Meetings should be held with village residents on a regular basis, to listen to their views and keep them informed of the programme's progress.

Where appropriate, handouts should be distributed to give residents full and comprehensive programme information.

Elaboration

To a great extent, the success of the programme will rely on how well the village residents are kept informed of the progress of the programme. The most important forum for this exchange is the *Kgotla*. Information to be presented at a *Kgotla* meeting should be discussed well ahead of time and printed on handouts which can be distributed at the meeting in conjunction with the oral presentation. Questions should be encouraged and answered at the *Kgotla* meeting. All important *Kgotla* meetings should be held near major public holidays to ensure that all members of the household (who are usually home for the holiday) are able to attend.

The following is a list of the meetings which should be held and their approximate dates. A brief outline of the kind of information which should be covered is also included.

Meetings and Handouts: Phase I/Year 1: June to November (see Figure 3)

June 1-10	Meet with the Village Development Committee (VDC) and Village Extension Team (VET) to explain the objectives and content of the Village Sanitation Programme. Topics to be discussed at this meeting include: <ol style="list-style-type: none"> 1. overall implementation schedule; 2. potential hiring of the Village Sanitation Coordinator (VSC) and Village Sanitation Assistants (VSAs); 3. construction procedures and costs; 4. demonstration latrines; 	
June 15-20		5. organizing a village-wide <i>Kgotla</i> meeting to obtain villagers' approval.
June 23-30		Distribute Handout A (see Appendix III) to primary school children.
		First <i>Kgotla</i> meeting. Topics to be discussed include: <ol style="list-style-type: none"> 1. reasons for and description of the programme; 2. schedule of events over the next six months; 3. date of follow-up meetings; 4. recruiting of VSC and VSAs.
		Distribute Handout B (see Appendix IV).
		Meet with VDC/VET to select VSC and VSAs.
July 1-5		
September 10-15		Meet with VDC to organize second <i>Kgotla</i> meeting for the end of September. Topics to be discussed include: <ol style="list-style-type: none"> 1. official opening of the demonstration latrines and invitations to the Paramount Chief, the local M.P. and Councilors to attend; 2. date and time for ceremony and <i>Kgotla</i> meeting; 3. agenda for <i>Kgotla</i> meeting.
September 17-22		Distribute Handout A to primary school children.
September 24		Demonstration latrines must be completed by this date.

September 25-30 Second *Kgotla* meeting. This meeting includes official opening of demonstration latrines by dignitaries. Topics to be discussed include:

1. construction methods;
2. use of local materials to reduce costs;
3. overall cost to householder and methods of payment;
4. explanation of contract and where to sign.

Distribute Handout C (see Appendix V).

October 1-15 VSC will visit all householders without latrines and explain the programme. This explanation should include:

1. what the contract is and what protection it offers;
2. how much householders pay;
3. what they receive for their money;
4. when they must pay;
5. when construction begins.

The object of this meeting is to encourage the householder to sign a contract.

Meetings and Handouts: Phase II/Year 1:
December to May (see Figure 4)

During Phase II, there will be almost no work for the VSC and VSAs because the villagers are at the lands. During this time the VSC should work half-time, visiting people who have signed contracts and reminding them to pay. There will most likely be other people who will want to sign contracts. The VSAs should continue to

receive their mobilization fee even though there will be little work. If payment were to stop, the VSAs might leave the programme for other jobs and new people would have to be hired and trained.

Meetings and Handouts: Phase III/Year 2:
June to November (see Figure 5)

June 1-5 Meet with VDC to organize third *Kgotla* meeting for the middle of June.

June 6-11 Distribute Handout A to primary school children.

June 12-16 Third *Kgotla* meeting. The purposes of this meeting should include:

1. payment of first 50 per cent, and reminders to save to pay the second half;
2. encouraging people to sign contracts;
3. scheduling for the next six months;
4. demonstration of construction techniques by VSAs.

Distribute Handout C (see Appendix V).

August 12-16 VSC should visit all householders building latrines to remind them that they must complete payment by August 31 if they are to receive a ventpipe and seat insert.

Pilot Project Experience

The distribution of accurate information was one of the most perplexing problems encountered by the Pilot Project. Most major problems resulted from misinformation or a total lack of information. It cannot be emphasized strongly enough how important this aspect of the project is. If it is done carefully and thoroughly, the programme should proceed with fewer problems.

Three different approaches were employed. The *Kgotla*, the traditional method of disseminating information, was used first. Attendance was fair to good in most villages. However, in Ranaka, where attendance was better than elsewhere, it still only amounted to about 7 per cent of the total village population. Since it was realized that this was not enough, efforts were then directed at ways of improving attendance at the meetings. The Pilot Project team drove through the village and announced the upcoming meeting over loudspeakers. This met with some success, but the cost of the equipment was considered beyond the means of most villages. However, if the District already has the equipment, then it should be used. The major problem with a public-address system is that it is only good for people in the village. Those at the lands cannot hear it.

Another method used to enhance *Kgotla* attendance was the distribution of *written notices* to schoolchildren one week before the

meeting. The results of this were very good and boosted attendance by more than 100 per cent. However, it required much advance planning and an additional trip to the village. When this advance notice included basic information about the project, it served two purposes and therefore was much more effective.

Towards the end of the Pilot Project, the VSCs were sent out to visit houses door-to-door in order to explain the contracts and the building procedure. This proved to be most effective. The situation that best illustrates this happened in Ranaka. During a well-attended *Kgotla* meeting, organized to explain the contract and encourage people to sign up, villagers were told that they should visit the Revenue Officer as soon as possible to sign contracts. After one week, only 11 contracts had been signed. The VSC, VSAs and the District Sanitation Foreman then visited every house and explained the procedures and offered to sign contracts. In the next three days, 104 more contracts were signed. Door-to-door visits are, by far, the best way to inform the villagers. While they are time-consuming and costly, the Pilot Project team members felt that the time and cost were well worth it.

6.2 Village Baseline Survey

Recommendation

A Village Baseline Survey should be conducted in each village under the direction of the Village Sanitation Coordinator.

Elaboration

A door-to-door Village Baseline Survey (see Appendix XIV) should be conducted under the direction of the Village Sanitation Coordinator (VSC) before any construction commences. This will serve three important purposes. *First*, it will collect essential information which will be needed to gauge the work that lies ahead. This information includes the number of occupied plots; the number of existing latrines; the number of people willing to undertake their own construction and to pay for materials; and identification of existing village groups or organizations which need to be contacted during the implementation process. *Second*, because the VSC must visit every household door-to-door, he has an opportunity to tell residents something about the

project, its objectives and its potential benefits. *Third*, as a result of the visits, the VSC will be more easily identified as the residents' main contact and will also be more aware of residents' attitudes towards health, self-help, etc. In other words, the survey is a critical part of the overall programme, and it serves as an important vehicle for communication.

In preparation for the survey, the District Sanitation Coordinator should ensure that the VSCs are trained in survey techniques and fully understand the questions being asked.

Pilot Project Experience

See Pia Kjaer-Olsen, *Environmental Sanitation and Protection Project: Report on Baseline Survey/Social Study of Pilot Villages* (Gaborone, February 1980).

6.3 Selection of Latrine Designs

Recommendation

The District Sanitation Planning Committee should approve appropriate latrine substructure designs for each village. Village residents should select their own superstructure design.

Scale models of optional superstructures should be made available for review by the Village Development Committee and village residents.

Elaboration

Following the completion of the Village Baseline Survey, the District Sanitation Coordinator (DSC) should meet with the Senior Public Health Engineer (SPHE), the Village Sanitation Coordinator and staff from the Departments of Geological Surveys (DGS) and Water Affairs (DWA) to select appropriate substructure designs for each particular village. Their choice should be approved by the District Sanitation Planning Committee and presented to the Village Development Committee.

Substructure Design: The design of the latrine substructure will be determined largely by cost, existing soil conditions, the presence of rock or other unpickable soils, and groundwater conditions. Assistance is needed from the DGS and DWA in determining the latter. Once subsurface conditions have been identified (or, if need be, investigated and tested in the field), the selection group should identify appropriate substructure designs based on the following guidelines:

- a) Rocky Areas: All latrines built on rock should use an unlined rectangular pit with a concrete ringbeam.
- b) Loose Soils: All latrines built on loose soils where the groundwater table is less than three metres below natural

ground level should use a round pit lined with trapezoidal brick.

- c) Vacuum Tanker Truck: All latrines built in a village which will be serviced by a vacuum tanker truck should also use a round pit lined with trapezoidal brick.
- d) Others: All other latrines should use a wire-mesh and filter-fabric lining.

Superstructure Design: Design options for the superstructures (or latrine buildings) will be determined largely by the nature of available local materials and local building techniques. The incorporation of these materials and techniques in the design is likely to ensure that the walls and roof can be constructed and afforded by householders.

Scale Models: The SPHE and the DSC should ensure that scale models and/or drawings of different design options are available for viewing by the selection committee and village residents. If carefully built, these models can be used to demonstrate how the latrine is assembled, how it eliminates odours and prevents the movement of insects, and how different superstructures can be used with common substructures.

Pilot Project Experience

Substructure Design: In fact, the demonstration latrines in all Pilot Project villages were built before detailed plans were completed for the optional substructures. Rectangular unlined pits with concrete ringbeams were built in Mabalane, Artesia, Olifants Drift, Ranaka and Selokolela (see Figures 14 and 15). Pits lined with wire mesh and filter fabric were built in sandy soils at Ranaka, Selokolela and Keng (see Figures 16 and 17). Two different options — one, where the pit was lined with trapezoidal bricks, and the other with curvilinear interlocking bricks — were also built at Keng (see Figures 16 and 17).

It was the experience of the Pilot Project that not all pits located in loose soils needed to be lined. For example, at Ranaka, over 100 unlined substructures were built in looser soil and, to date, none have collapsed. Generally, however, the extra cost of lining was found to be small, and all pits should be lined if there is any doubt about their stability.

From a cost point of view, the Pilot Project discovered that the round pit lined with wire mesh and filter fabric required one less slab (i.e., two in total) and a smaller concrete ringbeam than the others. In addition, it was found that the one pit lined with trapezoidal brick did not require a ringbeam. Thus, here were two lined pits which were relatively inexpensive.

Superstructure Design: Rectangular and circular wall-forms were chosen by the Pilot Project for more detailed investigation. Both were considered to provide village residents with a reasonable range of options as far as building materials and techniques were concerned. The major criterion for the wall-forms is that they block sunlight from reaching the latrine seat so as to discourage the passage of flies to and from the pit. The wall must also establish some privacy without a door being used, while at the same time leaving the

option for a door to be added later on. Builders in the Pilot Project chose their own materials, and these ranged from traditional mud-brick or cement-brick walls to thatched or corrugated-iron roofs.*

Scale Models: Many of the ideas for the ESPP latrine design had been developed before anything was built that could be used for demonstration purposes. It was necessary, however, to have some type of scale model that could be used for *Kgotla* and VDC meetings in the villages and for meetings with tribal, District, Ministry and donor officials. This problem was solved by building a small plywood and cardboard model that could be carried around in the back of a truck.

A model was built that represented two types of pits and three types of latrine buildings, with different roof types. For purposes of comparison, a square conventional-type latrine building was placed over a square pit to show how easy it was for such a building to collapse.

The ESPP-type latrine was then placed offset over a narrow trench to illustrate the advantage of this method of construction. The round and square wall shapes were also illustrated in order to stir up discussion on the potential building materials for walls, roofs and ventpipes.

Finally, the scale models proved to be valuable because many suggestions were made during these demonstrations that were eventually incorporated into the final latrine design.

6.4 Demonstration Latrines

Recommendation

Demonstration latrines should be built as examples to householders of good, yet inexpensive, latrine building technology. Sites for these latrines should be selected by *Kgotla* decision with the advice of the District Sanitation Coordinator. The demonstration latrines should be located where they will be seen by the greatest number of people.

Elaboration

The latrine designs developed as part of a village sanitation programme are likely to be different from conventional latrines both in design and in materials. Some demonstration is therefore needed both for the householders, who must decide whether or not to build, and for the Village Sanitation Assistants (VSAs), who will help those who choose to build. The construction of demonstration latrines by the VSAs will form an important part of their training. It also allows interested householders to watch the construction process and view the final product before being asked to pay for it. Finally, it establishes a more accurate base for cost estimates (see Appendix XV).

In keeping with project philosophy, the *Kgotla* should make the final decision on the location of the demonstration latrines. The District Sanitation Coordinator should advise the *Kgotla* prior to the decision being made. The latrines should be built where a maximum number of people can watch the construction process and see the final product.

They should not be built near a well or borehole or for public use except at the *Kgotla*.

Demonstration latrines may be built in *Kgotlas*, at schools, in private yards or any place they will be kept clean. *Kgotla* latrines are kept clean because of the ceremonial nature of the *Kgotla* itself. School latrines are cleaned because student labour is available. Household latrines are the responsibility of one family and are kept clean for their own exclusive use.

If private latrines are built by Council for demonstration purposes, the manner in which the households are selected is important. If villagers feel favoritism has been shown to an individual, for whatever reason, it may affect the popularity of the programme and adversely influence the number of people who choose to build latrines under the programme.

Pilot Project Experience

Demonstration latrines were built in all Pilot Project villages as the means of both introducing the householders to the construction component of the Pilot Project and investigating costs (see Appendix XV). Construction also served as training for the VSAs who built them, and established the building process that would be used in the eventual construction of household latrines. They were essential to the success of the Pilot Project and are likewise considered essential to the success of an expanded District programme. The demonstration models were built as *Kgotla* latrines, primary school latrines and private latrines. All of these sites have proven satisfactory.

1. Public Latrines

World-wide and local experience with public latrines has not been good. There is generally no one to clean and maintain them, and they quickly become eyesores and health hazards. This was the advice given at *Kgotla* meetings held to select sites for demonstration latrines. In spite of this advice, *Kgotlas* were chosen as sites for latrines in Ranaka, Selokolela, Mabalane and Artesia. The project team was told that a *Kgotla* latrine was important and that arrangements would be made for cleaning and maintenance. The team supported this approach and, as it turned out, the villagers were correct in all four cases. The latrines are

used and are kept clean at all times. This may be due to the pride taken in the entire *Kgotla* area as the special area for village activities.

2. Primary School Latrines

The *Kgotla* in Mabalane chose the primary school and primary school annex as sites for demonstration latrines. These proved especially beneficial as the latrines were thus introduced to all of the village children. The children saw firsthand that this latrine smelled less than other latrines with which they had experience. It is logical to assume that this information was transmitted to parents and was translated into more home latrines. School latrines are easily kept clean, since the headmaster will assign children the task.

3. Private Households

Demonstration latrines were built in private households in all the Pilot Project villages except Mabalane. The households were chosen in different ways in different villages. It was

thought that the *Kgotla* or the Village Development Committee would not be able to select a site without some people feeling that favoritism had been shown to the recipient. This could have an adverse effect on the adoption of the latrine by others. For that reason, a raffle system was used in Ranaka, Selokolela and Keng. A number was given to each of those attending the *Kgotla* meeting and a matching number was put in a hat. A number was then drawn from the hat by a child, and the person who had the matching number had a demonstration latrine built at his/her home by Council. This was considered fair and added some excitement to the *Kgotla* meeting. In Artesia and Olifants Drift, demonstration latrines were built in the homes of destitutes. This was also well accepted in these villages and was especially helpful to one woman in Artesia who is unable to walk.

6.5 Construction Training

Recommendation

The Village Sanitation Assistants should receive formal instruction from the District Sanitation Foreman in the construction of the approved pit latrines. They should then assist in the construction of the demonstration latrines and share their knowledge with village residents who decide to build their own latrines.

Elaboration

Both the Village Sanitation Assistants (VSAs) and the village residents need to receive training in the construction of the latrine types selected for their village. This should be accomplished in three steps:

First, the VSAs should receive formal instruction in construction techniques (see Appendix XVI). This instruction should be augmented by visits to previously completed latrines in other villages where construction may even still be in progress.

Second, the VSAs should learn from the practical experience acquired by constructing the village's demonstration latrines. Techniques to be learned include building a

ringbeam, lining the pit, placing slabs, building the foundation and superstructure, and installing the ventpipe and seat insert.

Third, with this knowledge in hand, the VSAs should be in a position to instruct village residents who want to save money by building their own latrines.

It is critical that the training be carried out carefully, using experienced teachers. The appearance and stability of the demonstration latrines, in particular, will be an influential factor in the village's choice to proceed with the programme or not. Ultimately, the VSAs' skill and ability to transfer it will determine the quality of the latrines which are built.

Pilot Project Experience

As the design and construction procedures used in the ESPP latrines were entirely new, everyone involved in building them had to be trained in each aspect of construction. It was decided that VSAs would be trained to build the latrines and that they would then train those in the village who were interested in building their own. This training was slow because it also served as a trial-and-error process of determining the best method of constructing the latrine. Each component was built for the first time during the construction of the demonstration latrines. This process included not only the building of demonstration latrines and the training of the VSAs, but also the determining of the best construction techniques.

During the building of the demonstration latrines in the villages, it was decided that ESPP model latrines should be built for publicity purposes at the Agricultural Show in Mochudi. These were the first demonstration

latrines to be completed. This caused an overall delay in building demonstration latrines in other villages but was beneficial, as it served as training for the two people who, a month later, were to become the District Sanitation Foremen (DSFs) in each District. The Works Department builder who was lent to the project for the Agricultural Show latrines was later assigned permanently as Project Foreman for Kgatleng District. The Construction Foreman for the Agricultural Show was later hired by the Southern District Water Department as half-time ESPP Foreman and half-time Rural Water Foreman. These two people then began to help with the training for and construction of the village demonstration latrines.

A two-day formal training session was held at the Denman Rural Training Centre to supplement the field experience. The main purpose of this session was to train the DSFs, VSAs and Village Extension Team members

in construction of the medium-cost, hessian-type latrine. Training in hessian technology was conducted by staff from the Selective Promotions Company, who were involved in marketing a round hessian latrine in Botswana. They brought with them components of a square hessian latrine designed to the Pilot Project's specifications. These were used to demonstrate the construction process. The

square hessian latrine at the *Kgotla* in Ranaka is one of the latrines originally used for training.

During the second day of this session, training was also given in lining the pit with wire mesh and filter fabric, building a ringbeam, marking out round walls by the double-radius method (later changed to a pattern) and building a mud-brick seat.

6.6 Household Latrine Construction

Recommendation

Householders should be encouraged to participate in the construction of their latrines to the greatest extent possible.

Elaboration

Most latrines can be built by householders, with advice and assistance from the trained Village Sanitation Assistants (VSAs), provided that local materials and familiar construction techniques are used. The following gives a rough outline of what the construction responsibilities should be:

1. *Ringbeam*: built by the VSA with assistance from the householder.
2. *Pit*: excavated by the householder under supervision of the VSA.
3. *Slabs*: placed by the VSA with assistance from the householder.
4. *Superstructure Foundation*: built by the VSA with assistance and building materials from the householder.
5. *Superstructure*: built by the householder under the supervision of the VSA.
6. *Ventpipe/Seat Insert*: installed by the VSA with assistance and building materials from the householder.

Pilot Project Experience

The Pilot Project explored various construction methods designed to include the householder. Some of these were as follows:

1. *Rectangular Pit with Ringbeam*

- a) Council transported ringbeam materials to the village.
- b) VSAs transported materials to household.
- c) Householder selected latrine site.
- d) Householder carried water to the latrine site.
- e) VSA built ringbeam (see Appendix IX).
- f) Householder excavated the pit inside the ringbeam to a depth of three metres.

2. *Round Pit with Wire-Mesh and Filter-Fabric Lining*

- a) Householder dug the pit to a depth of 2.4 metres.
- b) Council transported lining materials to the village.
- c) VSA installed the lining and ringbeam (see Appendix X).

3. *Round Pit with Trapezoidal-Brick Lining*

- a) Householder dug pit to a depth of between 2.5 and 3.0 metres and 1.15 metres in diameter.
- b) Council transported cement and moulds to the village.
- c) Householder or VSA made trapezoidal bricks.
- d) Householder or VSA lined pit with trapezoidal bricks (see Appendix XI).

4. *Slabs*

- a) Contractor made slabs (see Figures 11 and 12).
- b) Council transported slabs to the plot.
- c) VSA placed slabs over the ringbeam and pit.

5. *Wall Foundation*

- a) Householder furnished 40 bricks (9" x 6" x 4½") to the latrine site.
- b) Householder selected round or square wall shape.

-
- c) VSA built wall foundation around the edge of the wall pattern (see Figure 13).

6. Walls

Householder completed building walls with the advice of the VSA.

7. Roof

- a) Householder selected roofing materials.
- b) Householder roofed the latrine.

8. Hessian Ventpipe

- a) Contractor completed hessian ventpipe to the slurry stage (see Appendix XII).
- b) Council transported slurried ventpipes to the village.

- c) VSA stippled the ventpipe.

- d) VSA installed the ventpipe.

9. Seat Insert

- a) Contractor fabricated seat insert.
- b) Council transported seat insert to the village.
- c) Householder supplied mud bricks to latrine site.
- d) VSA installed seat insert.

6.7 Payment by Village Residents

Recommendation

Village householders should pay for the cost of all materials used in building their latrines.

A simple contract should be drawn up which states the contribution and responsibilities of both the District Council and the householder.

Elaboration

During the Pilot Project, it was discovered that village residents were reluctant to pay for their latrines in advance of construction. On the other hand, the District Council was reluctant to have villagers postpone payment until after the completion of construction because this could cause serious delays. With these two observations in mind, it is recommended that householders sign a contract (see Appendix VI) with the District Council, agreeing to pay for the cost of materials, in phase with construction, as follows:

1. The householder pays 50 per cent of the cost before the end of Phase I (see Section 3.4 — District Sanitation Plan).
2. Following the initial payment, the Village Sanitation Assistant (VSA) visits the plot and constructs the ringbeam.
3. The householder digs the pit.
4. The VSA ensures that the slabs are delivered and placed, and lays the first three courses of the superstructure foundation.

5. The householder pays the outstanding 50 per cent.
6. The seat insert and ventpipe are delivered and installed.

The advantages to this method of payment are:

1. A signed contract minimizes any conflicts.
2. In paying 50 per cent up front, the householder demonstrates his/her commitment to the programme and assumes responsibility for building the latrine.
3. Releasing the ventpipes and seat inserts after final payment reduces the risk of loss by the Council.
4. Splitting the payments allows the householder more time to save.

Pilot Project Experience

The original Pilot Project Paper called for half the householders to receive a subsidy in the form of building materials. Subsequently, however, local, District and Ministry staff attending the Project Planning Seminar decided that there should not be a subsidy until one was proven absolutely necessary. Council argued that transport could already be considered a form of subsidy. Following a series of further discussions between the Ministry of Local Government and Lands, the United States Agency for International Development and the Councils, it was decided that, while it was preferable to have householders pay in advance of delivery, this would not be possible during the early stages of the project.

Several arrangements for payment were tried. In Ranaka, Mabalane, Selokolela and Olifants Drift, people paid after receiving their materials. (By December 1982, about 60 to 70 per cent of the accounts were paid off in Ranaka and Mabalane; however, only 10 per cent had paid in Olifants Drift.) In Artesia, people were initially asked to pay the full amount in advance. However, in a month of door-to-door visits, only one person was prepared to sign a contract under these conditions. As soon as this arrangement was modified to phase payment with construction, an additional nine people signed contracts.

A side effect observed by the Pilot Project team was that, once a householder had paid, he/she took it upon himself/herself to ensure that the VSA attended to his construction duties on the householder's plot.

6.8 Revenue Collection

Recommendation

Payments for latrines should be collected by the local Council officer charged with the collection of other Council payments, provided this person is known to village residents.

Elaboration

There are a number of Council employees assigned to most villages. However, only three of them are permitted to collect money: the Revenue Officer, the Court Clerk and the Family Welfare Educator (FWE). One of these people must be selected to collect residents' payments for their latrine and materials. In determining who would be best for this job (it will vary from one village to

the next), it is important to remember that the person who is most familiar with, and to, the village residents will be able to undertake the task most effectively. The more time he/she spends in the village, the more likely that residents will be forthcoming with their payments. Experience has shown that, in most cases, the FWE is the best person to collect payments.

Pilot Project Experience

During the Pilot Project, an effort was made to use all three Council officers in the collection of residents' payments. The Revenue Officer collected money in Ranaka and Mabalane; the FWE in Keng, Artesia and Olifants Drift; and the Court Clerk in Selokolela. While one might assume that Revenue Officers were the officers most suited to the task, they did not always prove to be the best choice. As there are few of them, they are often required to cover a large area. This means spending less time in any given location. There was a Revenue Officer located in Ranaka, but he was often assigned collection duties in other parts of the District and was therefore away for long periods of time. The Revenue Officer from Mmatubudukwane collected payments in Mabalane. While she had transport to Mabalane only one morning per week and was unfamiliar with the location of people in the village, she did have the highest rate of collection of all collectors.

FWEs are located in most villages. They are selected from the village and are therefore familiar with its people. They do most of their work in that village, are associated in people's minds with health activities, and already collect health post fees. These are all strong points in favour of asking the FWE to collect payments. The FWEs who collected latrine payments during the Pilot Project generally did well. Some felt more commitment to the Pilot Project than others and therefore pushed harder to have people pay.

Court Clerks are also found in most villages and normally collect money in the normal course of their duties. To the extent that they are familiar with the village, they may also be chosen to collect payments. The low rate of payment to the Court Clerk in Selokolela is thought to be due more to lack of money in the village than poor performance on the Clerk's part.

6.9 Stores Controls

Recommendation

Stores controls and storerooms should be established for the sanitation programme at both the District and village levels.

Elaboration

District Level: Stores controls and regulations should be established for each District based on those already existing for other Council departments. The sanitation stores controls should be clearly separated from the others, and adequate storerooms identified for programme use. Stores should be administered by the District Sanitation Foreman (DSF) under the supervision of the District Sanitation Coordinator (DSC).

Village Level: A relatively simple set of stores controls should also be prepared for each

village. These should be administered by the Village Sanitation Coordinator (VSC) (see Appendices XVIII and XIX) — basically, to keep track of tools which are issued and materials received from the District. The VSC should be the only person responsible for signing out tools.

Inventory: An inventory of both the District and village stores should be carried out in June and December of every year, that is, at the end of each separate phase of construction.

Pilot Project Experience

In both Southern and Kgatleng Districts, corrugated-iron site buildings were used as storerooms. In Southern District, these buildings were at the Council Water Department and were supervised by the Council Stores Officer (CSO). Having the CSO keep the key caused a few problems because there were times when the DSF needed things from the stores when the CSO was not available. In Kgatleng District, the DSF kept the key, and this reduced problems considerably.

In most villages the corrugated-iron site buildings were found to be ideal because they were easy to transport, simple to put together,

weatherproof and easy to lock. In the villages where storerooms were not erected, other facilities were used. In Selokolela, the Village Development Committee (VDC) storeroom was used. This caused considerable problems because the key was kept by the VDC chairman, who left the village frequently. The storeroom also was not weatherproof, thereby causing the loss of much cement. In Keng, the health post was used and found to be very good. However, because Keng is a very small village, few supplies were needed.

6.10 Payment of Village Staff

Recommendation

The Village Sanitation Coordinator (VSC) and Village Sanitation Assistants (VSAs) should be hired on short-term (i.e., six-month) contracts.

The VSC should be paid a monthly salary at Council rates, and the VSAs should receive a monthly mobilization fee plus piece rates for all construction activities.

Elaboration

All village-level staff should sign six-month contracts (see Appendices XX and XXI) that will be renewed for as long as necessary. The VSAs should be paid a P20 mobilization fee (approximately P1 per working day). This is paid to cover the non-construction activities (e.g., mobilization of villagers) that the VSAs will be required to do. For construction activities, the VSAs should be paid by piece-rate, not by the day. Appendix XXIII presents a list of construction activities and the comparable pay for each activity. For example, if two VSAs install a ringbeam and the payment list indicates that P3 is paid for installing a ringbeam, they each get P1.50, not P3. However, if only one VSA installs a ringbeam, that person gets the entire P3. The VSC should keep a daily record of what each VSA does so that the payment sheet can be filled out at the end of the month (see Appendix VIII). It is the responsibility of the VSC to make sure the VSAs have completed what they are being paid for. The VSC should do spot checks to ensure that the quality of the work is up to standard. If it should be

necessary to use the VSAs as labourers (e.g., loading and unloading sand or latrine slabs), they should be paid a daily rate equal to what a Council labourer would get minus the P1 mobilization fee.

The VSC should be paid at Council rates on a monthly basis. Like the VSA, the VSC should submit a Construction Work Record (see Appendix XXII) to the Council Treasurer.

When hiring the VSC and VSAs, be sure to explain every aspect of their employment in detail. If this is not done carefully, one can anticipate trouble in the future. It would be wise to give them a copy of their contract and the Construction Activities Payment Sheet (see Appendix XXIII).

There should be a staff meeting of village staff on a monthly basis to talk over problems. The District Sanitation Coordinator, the District Sanitation Foreman, the VSC and the VSAs should all attend.

Pilot Project Experience

One of the most consistent problems experienced by the Pilot Project team was paying the VSAs. Almost every time a Pilot Project team member went into the village, a VSA had a complaint about his or her pay. To avoid these problems, a special effort should be made to explain to the VSAs before they start work how they will be paid and that they are temporary staff. They should then sign a contract and be given a copy with the list of construction activities and the amount they will be paid for each activity.

The reason for piece-rate payment is that, if villagers are to pay a set amount for the latrine, then the cost of installing the concrete ringbeam and building the foundation must also be set. If the VSAs were paid by the day, then the cost of the latrine would go up substantially. The amounts paid to the VSAs for each activity are based on the Council rate paid to casual labourers (i.e., P4.43 per day). If the VSA built only one ringbeam in a day, he/she received P3 for that and P1 as a mobilization fee, bringing the total to P4. It is

easy to build one ringbeam a day; in fact, most of the VSAs built two in one day, earning a total of P7 per day, above the average rate for unskilled labour.

On many occasions it was suggested that the VSC and VSAs be made permanent Council staff. There were several reasons why this was not done.

1. It is important to have village staff who know the village and the villagers well. When the project first hired VSCs, they were university students on long leave. These people worked very well but did not know the village and had great difficulty finding people to sign contracts. Whenever construction materials had to be delivered to householders, the VSCs did not know where to go, so a VSA had to be taken from whatever work he/she was doing to show where to find the house.

The successes the Pilot Project achieved in the villages were attributed to the fact that it was in the best interests of the VSAs to get people to build latrines. The more contracts, the more work.

When the university students returned to school, they were replaced with school-leavers from that village. These people had no difficulty doing the work and, in fact, were more effective when it came time to visit the householders to check on payments.

2. When the programme is finished, the VSA will no longer be paid by Council. However, just because the programme is moving to another village does not mean that there will be no more latrines built in that village. The hope is that the VSAs will start making contracts for piece-work and be paid directly by the householder.

This has already started happening in many villages. Throughout the Pilot Project, the VSAs were encouraged to take piece-work on the weekends. If the VSAs moved with the programme, there would be no one left in the village with the necessary skills to build the latrines. Also, by the end of the Pilot Project, the villagers get to know the VSAs and realize that they are the ones who can do the work and do it well.

3. Shortly before the programme moves to the next group of villages, the names of the VSAs should be given to the Rural Industries Officer (RIO). The RIO should visit these VSAs and help them to get started in their own business. Two things would be achieved. First, employment would be created at the village level, and, second, there would be a local business encouraging latrine construction. There are long-ranging benefits that could be achieved by this system. The Pilot Project team feels that there is an excellent opportunity here that should not be missed.
4. It is important that each person in the village believes that he or she can build a latrine. Having VSAs who are from the village, rather than Council professionals, will help in convincing people that it is an easy process that can be accomplished by all.
5. If VSAs are working in villages other than their own, housing and transport to programme villages will have to be provided by Council, and this would greatly increase the cost and complexity of the programme.

6.11 Purchasing

Recommendation

Quotations should be solicited from the suppliers of building materials and tools before any purchases are made.

Elaboration

Suppliers of tools and materials use two sets of prices. One is quoted over the counter to those who walk in off the street. The other is quoted to government agencies soliciting tenders. The latter is usually considerably

lower. Savings rendered through purchase by quotation can be used to build more latrines in the long run.

Pilot Project Experience

See Appendix XXIV.

7.0 Monitoring the Programme

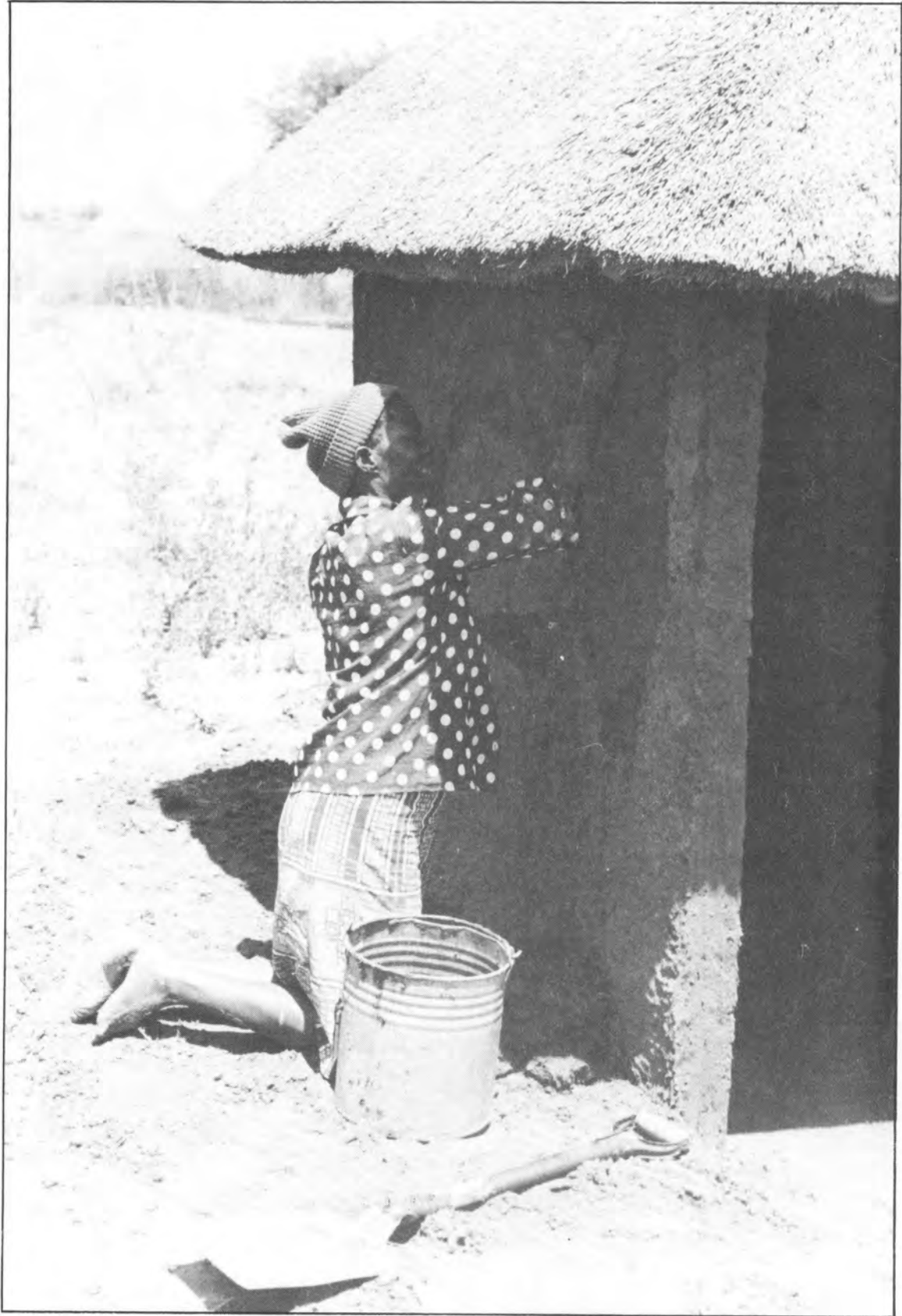

7.1 Monitoring the Programme

Recommendation

The District Sanitation Coordinator should ensure that ongoing physical, economic and social changes associated with the District and Village Sanitation Programmes are closely monitored and evaluated.

Elaboration

Completed village programmes should be monitored and evaluated during the period December to June, Phase II (see Figure 4) when there are fewer demands on the District Sanitation Coordinator (DSC). The DSC or his delegate should arrange to visit villages to talk with the village Headman and, where appropriate, to conduct house-to-house surveys in order to assess various results of the programme. Some examples of the kinds of questions which could be asked are given below:

Physical Changes

1. a) What is the total number of new latrines built under the District programme?
b) Are all the latrines completed?
c) Are all the latrines in good repair? If not, what are the principal problems being encountered?
d) What types of substructures/super-structures have been built?
e) Are the householders pleased with their latrines?
2. What effect have the new latrines had on the village water supply? (Ask the Department of Water Affairs to test the water at the borehole.)
3. Have all the substructures been lined within the proper distance from the boreholes? (Check with the Department of Geological Surveys.)
4. How many latrines have been built since the completion of the programme in this village?

Economic Changes

1. Has everyone who constructed a latrine under the programme paid for his/her building materials? If not, why not?
2. What is the current cost of a latrine?
3. Are the Village Sanitation Assistants still employed?

Social Changes

1. a) Do all household members who have access to a latrine actually use it?
b) If not, who does not and why not?
2. Why have people without a latrine not built one?
3. a) Has the incidence of diarrhoeal or intestinal disease been reduced since the end of the programme?
b) Can this be attributed to the new latrines?

Pilot Project Experience

The Pilot Project Paper called for monitoring of borehole water in Pilot Project villages to be sure that project-built latrines were not polluting the drinking water. Pollution of boreholes would be suspected if there was a significant increase in the numbers of indicator bacteria in water samples taken from the borehole after completion of a number of latrines. While this was, and still is, a valid concern in the building of latrines, it turned

out to be inapplicable in Pilot Project villages. The reasons are as follows:

Keng: No borehole; water comes from wells in Keng Pan that are highly polluted from animal wastes and buckets thrown in to draw water.

Selokolela: No borehole; water comes from wells in the valley passing through the centre

of the village and is highly polluted by animal wastes and buckets thrown in to draw water; the new borehole is eight kilometres from the village.

Ranaka: Borehole a kilometre from the village across the river; groundwater flow that would carry pollution from latrines to the borehole does not generally cross rivers.

Mabalane: Borehole two kilometres from village in area where cattle graze; any indicator bacteria found in water would more likely have come from cattle than from latrines in village.

Olifants Drift: Borehole one kilometre from village near river and beside path used by cattle to get to the river to drink; indicator bacteria would more likely have come from cattle than from latrines.

Artesia: Borehole in village, and possibility of pollution exists; nearest latrines are those built by Kgatleng Council for Council buildings; cattle and goats are frequently found within the borehole enclosure (the Pilot Project has a

picture of a goat standing on top of the pump); no way of knowing where any indication of pollution came from.

The potential for pollution of boreholes by pit latrines is great. Boreholes located in central Mochudi are well known to be polluted, and the many pit latrines there are an obvious source of that pollution. It is, however, impractical to require an entire village to build its pit latrines a few kilometres from the village. It is the borehole that must be sited in such a way that it will not receive pollutants from pit latrines that must be located at people's homes.

The Pilot Project also monitored its impact in the villages continuously on an informal basis and periodically on a formal basis. The comments of those building their own latrines as to likes or dislikes and ease or difficulty of building served as feedback to the Pilot Project. Revisions were made accordingly. Regular technical and social impact evaluations were carried out that were very helpful in the ongoing improvement of the approach.

8.0 Appendices



APPENDICES

Appendix	I	Hydrogeological Criteria for the Selection of the Six Villages in the ESPP	73
Appendix	II	Summary Descriptions of the Six Pilot Project Villages	74
Appendix	III	Handout A — Announcement of <i>Kgotla</i> Meeting	76
Appendix	IV	Handout B — The District Sanitation Programme	77
Appendix	V	Handout C — Building Your Own Latrine	78
Appendix	VI	Householder's Latrine Contract (English and Setswana)	79
Appendix	VII	Planning and Report Form	81
Appendix	VIII	Village Latrine Inventory	82
Appendix	IX	Construction of Rectangular Pit with Ringbeam	83
Appendix	X	Construction of Pit Lining with Wire Mesh and Filter Fabric	84
Appendix	XI	Lining of Pit with Trapezoidal Bricks	85
Appendix	XII	Construction of Hessian Ventpipes	86
Appendix	XIII	Compressor and Jackhammer	87
Appendix	XIV	Village Baseline Survey Form	88
Appendix	XV	Cost of Demonstration Latrines	90
Appendix	XVI	Training Programme, Task Analysis — District Sanitation Coordinator and Village Sanitation Coordinator	92
Appendix	XVII	Training Programme, Task Analysis — Village Sanitation Assistants	93
Appendix	XVIII	Village Stores Control (Tools)	94
Appendix	XIX	Village Stores Control (Building Materials)	95
Appendix	XX	Village Sanitation Coordinator's Contract (English)	96
Appendix	XXI	Village Sanitation Assistant's Contract (Setswana)	97
Appendix	XXII	Construction Work Record	98
Appendix	XXIII	Construction Activities Payment Sheet	99
Appendix	XXIV	Availability of Construction Materials	100

Appendix I

Hydrogeological Criteria for the Selection of the Six Villages in the ESPP

1. No village should be selected whose waste products from the latrines in the pit-latrine construction programme will have a negative influence on the water quality of the groundwater supplies in the village. (Minimum requirements — no new pit latrines around boreholes or open wells.)
2. The groundwater pollution monitoring programme, which hopefully will be carried out in three of the six villages, requires that the pit-latrine construction programme be conducted in villages with different thicknesses of soil cover. One village ought to be a village with Kalahari-sand, another village with a thin soil cover and shallow groundwater table. (The groundwater should, in the latter case, not be used as the water supply.)
3. Recommended measures to protect against pollution of the drinking water should be included in the education campaign in the ESPP. Therefore, different types of water-quality problems ought to be represented.
 - a) One village ought to be a cattle-keeping village, with large numbers of cattle around the water supply and in the village.
 - b) One village should have open wells as the only water supply, e.g., Kokong.
4. From a public health point of view, one of the villages should be representative of the kind of village that has health problems often related to polluted surface water, a dam or a small stream.

Hans Lann
Senior Water Engineer (Pollution)
Gaborone, 7th November, 1979

Appendix II

Summary Descriptions of the Six Pilot Project Villages

Kgatleng District Council selected the following villages:

Artesia

- Approximate population — 566
- Terrain — sandy
- Water — borehole with standpipes at Railway Camp, school and clinic
- Economy — predominantly cattle; employment at railway station
- People — predominantly Bakgatla, Bakwena, Bakgalagadi and Basarwa. Railway Camp consists of people from other parts of Botswana
- Density — fairly dispersed except at Railway Camp
- Accessibility — good dirt road with regular transport to major centres

Mabalane

- Approximate population — 681
- Terrain — rocky, with possible high water table
- Water — dam, river and standpipes (if the borehole is pumping sufficient water)
- Economy — mixed; cattle and arable agriculture with a large number of migrant labourers
- People — predominantly Bakgatla
- Density — houses in very close proximity to each other
- Accessibility — good dirt road with regular transport to major centres

Olifants Drift

- Approximate population — 323
- Terrain — rocky, with possible high water table
- Water — borehole and river
- Economy — mixed; cattle and arable agriculture with a large number of migrant labourers
- People — predominantly Bakgatla
- Density — very dispersed
- Accessibility — remote; poor dirt road with patches of heavy black mud; transport to major centres very irregular

Southern District Council selected the following villages:

Ranaka

Approximate population—	1,914
Terrain	— hardveld and rocky
Water	— borehole with reticulation and dam
Economy	— mixed; arable agriculture and livestock
People	— Bangwaketse
Density	— households fairly close together in parts
Accessibility	— good; about 15 kilometres from Kanye

Selokolela

Approximate population—	512
Terrain	— boundary between sandveld and hardveld
Water	— hand-dug wells and rain catchment areas
Economy	— mixed; arable agriculture and cattle
People	— Bangwaketse and Bakgalagadi
Density	— dispersed
Accessibility	— fairly isolated; about 14 kilometres from Moshaneng

Keng

Approximate population—	387
Terrain	— sandveld
Water	— hand-dug wells
Economy	— predominantly cattle
People	— Bakgalagadi (Baswaela), Bangwaketse and Balala
Density	— very dispersed
Accessibility	— very remote; heavy sand road and irregular transport

Appendix III

Handout A — Announcement of *Kgotla* Meeting

Instructions: To be printed in Setswana for distribution to schoolchildren at beginning of programme [see Figure 3].

Many people throughout _____ District have told Council that they wish to improve sanitation in their villages. In response to this, Council has developed a District Sanitation Programme which will help people accomplish this improvement. Last year, this programme was introduced in Ranaka, Selokolela, Keng, Artesia, Mabalane and Olifants Drift and, as a result, over 250 householders have completed their own latrines.

District Council will soon be selecting villages for this year's programme. Thus, Council officials will be visiting _____ on _____ at _____ to discuss the programme and its objectives and to answer questions.

If you are interested in seeing a District Sanitation Programme introduced in your village, please attend this meeting and bring along your family and neighbours. If the village accepts this programme, you could be building a new latrine for yourself within a year or so.

Sincerely,

(District Sanitation Coordinator)

Appendix IV

Handout B — The District Sanitation Programme

Instructions: To be printed in Setswana and distributed to all householders in each programme village [see Figure 3].

_____ District Council's Rural Sanitation Programme is about to be introduced in your village. The main objective of this programme is to help you protect your family from disease by ensuring that rubbish and human excreta are not left in the open air where flies can carry germs from them to your food. This programme will show you how to build a proper latrine for your family and a pit for your rubbish. These can be built by you for a small amount of money.

In the next two months or so, the Village Sanitation Coordinator and the Village Sanitation Assistants selected from your village will be constructing demonstration latrines in the village. You can watch to see how these are constructed. When they have been completed, a meeting will be called at the *Kgotla* to discuss your opinions. At that time you will have to decide whether or not you want to build a latrine like one of these for your own use.

If you decide you want to build your own latrine, the procedure will be outlined at this *Kgotla* meeting. You will also be informed of the cost and method of payment. You will need to decide where to build the latrine, what shape you prefer, and what materials you wish to use. The Village Sanitation Assistants will be available to assist you in constructing your new latrine.

So watch the demonstration latrines being built, talk about them with your family and friends, decide if you want to build your own and come to the *Kgotla* meeting when it is announced.

(District Sanitation Coordinator)

Appendix V

Handout C — Building Your Own Latrine

Here is how you can build your own latrine with the help of the District Council.

1. First, you will be required to pay P_____ for the materials that Council will bring to you.
Half of the total payment, P_____, must be paid before 1st July. The second half, P_____, must be paid by 31st August.
2. After you have paid the first half, the Village Sanitation Assistant will visit your house and, with your help, construct a concrete ringbeam. When this is done, you will have to dig the pit. When the pit is finished, you should contact the Village Sanitation Coordinator in your village and he will send the Village Sanitation Assistant back to your house. Then, with your help, the Village Sanitation Assistant will place the slabs over the pit and build a foundation for the superstructure with the mud (or concrete) bricks you have made.
3. Following that, it will be time for you to build the latrine superstructure and put the roof on.
4. After the second payment is made, the Village Sanitation Assistant will bring your ventpipe and seat insert and help you install them.

See how easy it is to build your own latrine. This offer is only good for this year. Next year, the programme will move to another village.

(District Sanitation Coordinator)

Appendix VI
Householder's Latrine Contract

I _____ of _____ village,
_____ District, agree to pay the sum of _____
Pula to the Council Revenue Officer.

In return for this fee _____ District Council will
provide me with:

- a) 3 latrine slabs
- b) 1 ventpipe
- c) the technical assistance necessary to construct my own latrine
- d) 1 3-metre piece of Typar
- e) 1 3-metre piece of wire mesh
- f) labour and materials necessary to install a reinforced concrete
ringbeam

(Delete that which does not apply)

The terms of payment will be _____

Signature of Home Owner _____ Date _____

Signature of Headman _____ Date _____

Signature of Council Secretary _____ Date _____

Maitlamo a Mong Wa Nilwana Ya Boithomelo

Nna _____ wa _____ motse wa
_____ O o mo kgaolong ya
_____. Ke itlamo go duela madi a P _____, ke
a neela mophuta madi wa Khansele.

Fa ke duetse madi a _____ Khansele e tla nneela:

- a) Dikhurumelo kana diselebe tsa mosima wa ntlwana ya boithomelo di le tharo (3).
- b) Pompo ee ntshang mowa e le nngwe fela (1).
- c) Setilo sa ntlwana ua boithomelo.
- d) Baitseanape ba matlwana a boithomelo.
- e) Wairi le polasetiki ee itsand gore mosima o seka wa wela.
- f) Ditena tse di itsang gore mosima o seka wa wela.
- g) Dilo tse di agang lesaka la mosima.

Ke tla duela jaana P _____ Kgwedi le kgwedi go
Fitlhela ke fetsa.

Seatla sa mong wa lwapa _____ Kgwedi _____

Seatla sa Kgosi/Kgosana _____ Kgwedi _____

Seatla sa Mokwaledi wa Khansele _____ Kgwedi _____

**Appendix VII
Planning and Report Form**

Plan for the week of: _____ District: _____ Name/Designation _____

Monday	Tuesday	Wednesday	Thursday	Friday	Saturday
					Sunday

Record of Actual Work

Monday	Tuesday	Wednesday	Thursday	Friday	Saturday
					Sunday

Prepared by: _____ Date: _____ Approved: _____ Date: _____

Appendix VIII Village Latrine Inventory

Village _____ Village Sanitation Assistant _____

Name of Builder	Ringbeam Completed	Pit Dug	Wire/ Typar Placed	Slabs Delivered	Slabs Placed	Foundation Completed	Walls Completed	Ventpipe Delivered	Roof Completed	Seat Completed	Payment

Instructions: Record date on which each activity is completed.

Appendix IX

Construction of Rectangular Pit with Ringbeam

(see Figures 14 and 15)

1. Village Sanitation Assistant (VSA) places ringbeam pattern, 850 mm by 1550 mm, in north-south direction over site of latrine and stakes down the corners.
2. VSA digs trench, 125 mm by 125 mm, around the outside of the pattern.
3. VSA bends a 6-metre length of 8-mm reinforcing bar in the shape of the trench.
4. VSA fills trench with cement, placing the bent reinforcing bar in centre with 25-mm cover, and allows to cure and dry.
5. Plot-holder excavates pit inside rim to depth of 3 metres.

Appendix X

Construction of Pit Lining with Wire Mesh and Filter Fabric

The wire-mesh and filter-fabric lining is a low-cost method of supporting a latrine pit from collapse due to poor soil structure. It should be used in areas where the probability of using a vacuum tanker pump truck to empty a full pit is small. This will be in village areas remote from District capitals.

This type of lining is simple and inexpensive. The following steps should be followed in lining the pit:

1. Dig the pit 0.9 metres in diameter and to a depth of 2.4 metres. This diameter should be maintained as closely as possible.
2. Unroll 14 sections of 193 wire mesh, being careful not to bend the wire. (A roll is superior to a flat sheet because it is already bent at the desired curvature and will be stronger in resisting outside forces in hoop compression.)
3. Cut wire with bolt-cutter in centre of 15th section.
4. Rewrap the mesh in a circle and bend the cut ends around the first transverse wire with pliers.
5. Unroll 3.2 metres of filter fabric cut to a width of 2.1 metres (half of 4.2-metre-width roll).
6. Cut with scissors or knife.
7. Wrap filter fabric around wire mesh so that the edge of the fabric is even with the first wire at one end. Pull tight.
8. Fasten the filter fabric together at the overlap with four or five long thorns or short pieces of wire.
9. Drop the assembly into the pit with the matched ends at the top.
10. If the pit has been incorrectly dug and is too wide, backfilling may be necessary at this point.
11. Dig a circular trench, 125 mm by 125 mm, around the top of the assembly.
12. Bend the exposed 100-mm ends of wire mesh outwards into trench. This will be a 180-degree bend.
13. Fill trench with wet cement mixture and allow to dry.
14. Place slab or slabs.

Appendix XI

Lining of Pit with Trapezoidal Bricks

(see Figures 15 and 17)

Trapezoidal (Trap) bricks are ideal for lining a latrine pit. They can be constructed on site using available sand with a low cement/sand ratio. They are made with a simple mould in the way mud bricks are traditionally made.

Steps to completion of the pit are simple. First, a pit 1.3 metres in diameter is dug to the desired depth — usually 2 to 3 metres. It is important that the walls of the pit be straight and vertical. It is also important that the bottom be flat and level. The first ring of bricks should be placed with a level. After that it is just a matter of stacking, making sure each new course covers the joints in the course below it.

If there is any question of settling, each brick of the first course should be set on a piling (see Figure 9). This is made from a straight stick 300-350 mm in length and 30-50 mm in diameter. It is sharpened at one end and driven into the earth below the brick with a hammer. The brick is then placed and levelled. Each succeeding brick of the first course is placed the same way.

When the lining is completed to the top, the slab can be placed directly over it. A pit lined in this way may be pumped and reused.

Appendix XII

Construction of Hessian Ventpipes

The stippled-wire-and-hessian ventpipe is an inexpensive alternative to fibreglass or plastic pipes. However, the construction must be well organized and supervision is required.

The ventpipes are constructed as follows:

1. The roll of wire mesh is 2.4 metres wide. Cut across the roll just before the 12th transverse wire. This will yield a piece 10 squares wide and leave an end wire.
2. Wrap the piece in a circle and fasten it by folding the cut ends around the first transverse wire of the other side.
3. Choose one end of this tube on which to place the flyscreen and bend the wire ends to the inside perpendicular to the pipe.
4. Cut a 300-mm square of fibreglass flyscreen.
5. Hessian is available in rolls 1.8 metres wide; cut this lengthwise in thirds to a width of 0.6 metres.
6. From these, cut pieces 2.4 metres long and wrap tightly around the wire mesh.
7. Place flyscreen over one end and tuck inside the hessian.
8. Sew in the flyscreen along the cut edge of the hessian with a large curved needle and twine.
9. Mix well 6 kg salt, 50 kg cement and 70 litres warm water in a long horizontal bath (made from a 200-litre drum cut in half and welded end to end). Allow salt to dissolve. Stir continuously throughout the process to prevent cement from settling.
10. Roll each ventpipe slowly in the bath, making sure it is well soaked. Stand to dry. This will not plug the flyscreen. Pipes can now be stored for transport to latrine sites.
11. Mix 6 parts sand, one part cement and water to the consistency of thick soup (some experimentation may be necessary to get the consistency correct the first time).
12. Throw this mixture onto the pipe with a large plastering brush, covering it completely except for the flyscreen. Keep moist for 4 days and then allow to dry.
13. The pipe may now be plastered for extra rigidity, as the wire may corrode over time.
14. Install ventpipe on latrine.

Appendix XIII

Compressor and Jackhammer

Recommendation

In villages characterized by a shallow horizon of rock or unpickable soils, District Council should be prepared to use a jackhammer to excavate latrine pits, provided householders are prepared to contribute towards the cost.

Elaboration

Most of eastern Botswana is characterized by the existence of rock or unpickable soils which can hamper surface excavations. Previously, the presence of rock had discouraged village residents from building pit latrines. However, in some villages, a jackhammer can be used successfully for these purposes.

Pilot Project Experience

The Pilot Project team initially rented two compressors to dig pits in Mabalane. Pits, varying from 1.5 to 2.5 metres in depth, were dug in a single day, depending on the rock texture.

One of the two compressors was rented from Kgatleng District for P30 per day. Three labourers were required to run the compressor and each was paid P5.95 per day. This compressor used a total of 3 barrels of diesel fuel in the 18 days it was used at Mabalane.

The second compressor was rented from Maxwell at P108 per day, including labour but excluding fuel. This compressor used 4.5 barrels of diesel fuel in 17 days.

$$\begin{aligned}\text{Total average cost per pit (as of July 1982)} &= \frac{108 + 30 + (3)(595)}{2} \\ &= \text{P83.83 each (excluding fuel)}\end{aligned}$$

Householders were asked to contribute P6 of this amount.

At Olifants Drift, the Pilot Project team experimented with a different machine — a jackhammer. This smaller machine is more easily handled and can be easily transported on a regular pick-up truck. After testing an older machine, the Pilot Project team purchased a new jackhammer for Kgatleng District at a cost of P2,500. This machine digs a 2.5-metre-deep pit in 1.5 days. It is operated by one labourer who is paid P16 per day, and it uses 1.5 litres of diesel fuel per pit.

$$\begin{aligned}\text{Total average cost per pit} &= 16 + (0.70)(1.5) \\ &= \text{P17.05 per pit (including fuel)}\end{aligned}$$

In summary, the jackhammer proved considerably more advantageous than the compressor. Its use also means that plot-holders can be requested to pay a larger proportion of the costs, say, P8 per pit.

Appendix XIV
Village Baseline Survey Form

1. Name of head of household
2. Names of other householders
3. Number of other people living here

PEOPLE LIVING IN HOUSEHOLD						
Name	Sex	Age	Working		Not Working	Student
			In Village	Outside		

4. How many times has someone in the family had stomach sickness in the last year?
5. Have you ever lost money at the Botswana Meat Commission because of measles in your cattle?
6. Are you aware that using a latrine can improve your health and prevent your cattle from getting measles?
7. Do you have a latrine?
 - If yes:
 - a) Did you build it yourself?
 - b) Did you hire someone to build it for you?
 - c) How much did it cost?
 - d) Did you line the pit with bricks? Do you think it was necessary to line the pit?
 - e) Did you hit rock in the pit? If so, what did you use to break the rock?
 - f) Did you hit water in the pit?

- g) When was it built?
- h) Do the children use it? If no, why don't they use it?
- i) Why did you built it?

If no,

- a) Do you want a latrine?

If yes:

- i) Why haven't you built one?
- ii) Would you be willing to pay P _____ for the materials for a latrine you build yourself?
- iii) Is there someone who lives here who could help to build a latrine?

If no:

- i) Why don't you want a latrine?

Appendix XV

Cost of Demonstration Latrines

The quantities included in this calculation of costs of building demonstration latrines are (1) the retail costs of the materials for the project; (2) the transport of those materials to the villages; and (3) the labour cost of building the latrines, paid mostly to Village Sanitation Assistants. Not included are salaries of Council staff who organized or supervised construction or drove. Also not included is a factor for any waste and loss of building materials that may have occurred.

The unit prices of materials for the demonstration latrines were as follows (as of July 1982):

Item	Quantity	Price
Cement	50 kg packet	P3.05
Reinforcing mesh	193 mesh 2 m x 2.4 m	P7.20
Reinforcing bar	6 m x 8 mm	P1.78
Ventpipe (pvc)	3 m x 160 mm	P23.00
Roofing grass (<i>motsikiri</i>)	200-mm bundle	P0.16
Roofing twine	1 kg	P1.85
Roofing wire	1 kg	P0.78
Rafters (<i>dithlomeso</i>)	Unit	P0.50
Perlins (<i>dipalelo</i>)	One roof	P4.00
Supports (<i>meotwana</i>)	Unit	P0.50
Perimeter perlins (<i>mepako</i>)	Unit	P0.25
Gravel	m ³	no cost
Sand	m ³	no cost
Water	1 litre	no cost

Transport cost of materials was calculated in the following manner. All materials for demonstration latrines were transported in Council J5 Bedford 5-ton trucks. Total running cost of these trucks is P0.55 per kilometre. A total of 14 demonstration latrines were built in Southern District and 13 in Kgatleng District.

In each District, one trip to Gaborone would be required to return the required materials to the District capital. One additional trip would be required to each village from the District capital to deliver these materials. An additional trip or two to a site within or near the village would be required to collect sand, gravel and roofing materials. The cost of the trip to Gaborone is divided equally over all demonstration latrines built in the District. The cost of the delivery trip to the village is divided over all latrines built in that village.

These costs are as follows:

Trip	Distance Return (km)	Total Cost (July 1982)	Cost per Latrine
Gaborone- Mochudi	100	P55.00	P4.23
Mabalane- Mochudi	115	P63.25	P12.65
Artesia- Mochudi	200	P107.25	P17.88
Olifants Drift- Mochudi	225	P126.50	P63.25
Gaborone- Kanye	270	P148.50	P10.61
Ranaka- Kanye	75	P41.25	P5.16
Selokolela- Kanye	100	P55.00	P18.33
Keng- Kanye	435	P239.25	P79.75

The extra 25 kilometres in village trips is to load sand and collect roofing materials locally.

The labour cost was determined from a schedule that was given to each Village Sanitation Assistant as the basis for his or her payment. The rates were set in such a way that a person pursuing a given activity for an 8-hour day would earn approximately the minimum wage of P4.43.

Appendix XVI

Training Programme

Task Analysis — District Sanitation Coordinator

1. Plan of procedures — importance of advance planning
2. Council procurement procedures
3. Completion of payment sheets — costs and prices of labour and commodities
4. Compiling questionnaire results
5. Importance and functioning of latrine
6. Basic health
7. Basic latrine building procedure
8. Organize courses for District Sanitation Foremen and Village Sanitation Coordinators

Task Analysis — Village Sanitation Coordinator

1. Working with Village Extension Team
2. Completion of payment sheets — cost and prices of labour and commodities
3. Administering questionnaire
4. Importance and functioning of latrine
5. Basic health related to fecal diseases
6. Basic latrine building procedure

Appendix XVII

Training Programme

Task Analysis — Village Sanitation Assistants

1. Reasons for building a latrine
2. Principles of latrine design
3. Place pattern
4. Dig trench around pattern
5. Mix concrete
6. Place concrete
7. Cure concrete
8. Dig pit
9. Place slabs
10. Build mud-bricks
11. Use wall patterns
12. Build foundation
13. Build walls
14. Make trapezoidal bricks
15. Place trapezoidal bricks
16. Set mini-piling (if necessary)
17. Level bricks
18. Alternative wire-mesh and filter-fabric lining

Appendix XVIII

Village Stores Control (Tools)

Item Name	Quantity	Date Taken Out	Date Returned	Signature of Person Taking Tools

Appendix XIX

Village Stores Control (Building Materials)

Item Name	Quantity	Date Received	Date Given Out	Signature of Village Sanitation Coordinator

Appendix XX

Village Sanitation Coordinator's Contract

_____ has been hired for the 6-month period from
_____ to _____ by the
_____ District Council at the rate of pay of
P_____ per month. The above-named person will work full-time/part-
time in the Village of _____ and will be responsible for
the satisfactory completion of the tasks on the attached Job Description (see
Secton 4.4). Two weeks' notice of termination must be given by either the
contractor or the contractee.

Signature of Contractee _____ Date _____

Signature of Council Secretary _____ Date _____

Signature of Headman _____ Date _____

Appendix XXI

Maitlamo a go Thapa Baagi Ba Matlwana a Boithomelo

Nna _____ ke thapilwe ke Khansele go thusa mo kagong ya matlwana a boithomelo mo motseng wa _____

Maitlamo a mpateletsa go dira mo motseng malatsi a le matlhano, go tsweng ka _____ go fitlhelela ka _____, Ga ke ne go dira ka malatsi a boikhutso a ga Goromente.

Ke tla duelwa _____ gore ke se ka ka tswa mo motseng ka nako ya tiro. Ke tla amogela ka kgwedi.

Ke itlama go dira tiro nngwe le go gakolola kana go thusa beng ba matlwana a boithomelo. Ke tla duelwa ka fa maitlamo a A a buang ka teng. Ke tla duelelwa ntlwana nngwe le nngwe e ke thusitseng gore e agwe.

Seatla sa mothapiwa _____ Kgwedi _____

Seatla sa Kgosi/Kgosana _____ Kgwedi _____

Seatla sa Mikwaledi wa Khansele _____ Kgwedi _____

Appendix XXII
Construction Work Record

FROM: District Sanitation Coordinator

TO: Council Secretary

DATE: _____

Construction Work Record

Please furnish me with cheques for the following activities:

NAME: _____

VILLAGE: _____

Date	Work Completed	By How Many Workers?	Rate From Payment Schedule	Amount To Be Paid	
Subtotal					
Mobilization Fee					
TOTAL					

Signature of District Sanitation Coordinator _____

The rate from the payment schedule, divided by the number of workers, should equal the amount to be paid.

Appendix XXIII

Construction Activities Payment Sheet

Digging pit	P10.00
Digging one cubic metre of mud for bricks	P 1.00
Digging and pouring concrete rim	P 3.00
Levelling and installing first row of trapezoidal bricks (including making pilings)	P 1.50
Installing wire	P 1.00
Making 200 mud bricks (approximately 9" x 8" x 4")	P 9.00
Constructing mud walls	P10.00
Smearing walls with mud/dung mixture (twice)	P10.00
Loose-thatch roof (including framing)	P10.00
Professional thatch roof (including framing)	P30.00
Building foundation (including placing slabs)	P 3.00
Stippling ventpipe	P 0.50
Installing ventpipe	P 0.50
Installing plastic seat insert	P 1.00

Appendix XXIV

Availability of Construction Materials

All project materials for demonstration latrines and for household latrines were purchased in Gaborone, although some were ordered specially from South Africa. Below is a list of materials used and potential suppliers.

Item	Supplier
No. 193 wire mesh (2.4-m x 60-m roll — 200-mm grid)	BMB or Haskins
Ventpipe wire mesh (2.4-m x 30-m roll — 2-mm x 50-mm grid)	BMB (by order) at least two months in advance
Hessian (1.83-m width)	BMB or Haskins
Filter fabric (4.2-m x 100-m roll)	BMB (by order) at least two months in advance
Salt (50-kg sack)	Kanye Co-operative
Block moulds	RIIC (Kanye) or Cliff (Gaborone) (by order)
Rectangular slab wire mesh, Reference Jo433 (6 m x 2.4 m)	BMB (by order) at least two months in advance
Reinforcing bar (8 mm x 6 m or 13 m)	BMB or Haskins
Cement (50-kg packet)	Anywhere
Flyscreen (4' x 100' roll fibreglass)	Gaborone Hardware

9.0 Figures

FIGURES

Figure 1	District Sanitation Programme	103
Figure 2	District Sanitation Programme: Setting Up	104
Figure 3	Village Sanitation Programme: Phase I	105
Figure 4	Village Sanitation Programme: Phase II	106
Figure 5	Village Sanitation Programme: Phase III	107
Figure 6	Programme Organization Chart	108
Figure 7	Plan and Elevations of Circular Brick	109
Figure 8	ESPP Trapezoidal Brick	110
Figure 9	Trapezoidal Brick Supported on Small Piling	111
Figure 10	Trapezoidal Brick Pit	112
Figure 11	ESPP Rectangular Slab	113
Figure 12	ESPP Circular Slab	114
Figure 13	Circular and Rectangular Superstructure Wall Patterns	115
Figure 14	BOTVIP Latrine Type A1 — Plan and Section	116
Figure 15	BOTVIP Latrine Type A2 — Plan	118
Figure 16	BOTVIP Latrine Type B1 — Plan	119
Figure 17	BOTVIP Latrine Type B2 — Plan and Section	120
Figure 18	BOTVIP Seat Insert — Plan and Section	122

Figure 1
District Sanitation Programme

ACTIVITY	YEAR 1					YEAR 2					YEAR 3															
	J	F	M	A	M	J	J	A	S	O	N	D	J	F	M	A	M	J	J	A	S	O	N	D		
SETTING-UP																										
IMPLEMENT CLUSTER 1						Phase I					Phase II					Phase III										
Village A																										
Village B																										
Village C																										
Village D																										
Village E																										
IMPLEMENT CLUSTER 2												Phase I					Phase II					Phase III				
Village F																										
Village G																										
Village H																										
Village I																										
Village J																										
IMPLEMENT CLUSTER 3																	Phase I									
Village K																										
Village L																										
Village M																										
Village N																										
Village O																										

Figure 2
District Sanitation Programme: Setting Up

ACTIVITY	DEC	JAN	FEB	MAR	APR	MAY
1. APPOINT DISTRICT SANITATION COORDINATOR	■					
2. FORM DISTRICT SANITATION PLANNING COMMITTEE		■				
3. TOUR PREVIOUSLY IMPROVED VILLAGES		■				
4. DISTRICT COMMITTEE MEETINGS		●		●	●	●
5. SELECT VILLAGES TO BE IMPROVED		■				
6. PREPARE DISTRICT SANITATION PROGRAMME		■	■	■	■	
7. SELECT DISTRICT SANITATION FOREMEN				■		
8. TRAIN DISTRICT SANITATION FOREMEN					■	■

Figure 3
Village Sanitation Programme: Phase I

ACTIVITY	JUN	JUL	AUG	SEP	OCT	NOV
1. MEET WITH VDC/VET	●	●		●		
2. DISTRIBUTE HANDOUT A	●			●		
3. KGOTLA MEETING – DISTRIBUTE HANDOUT B		●		●		
4. SELECT VSC AND VSAs		■				
5. PLAN TRAINING SESSION		■				
6. CONDUCT TRAINING SESSION		■				
7. ASSEMBLE MATERIALS FOR DEMONSTRATION LATRINES		■				
8. CONSTRUCT DEMONSTRATION LATRINES		■	■	■	■	
9. CONDUCT VILLAGE SURVEY (VSC)			■	■		
10. CONDUCT HOUSE-TO-HOUSE VISITS (VSC)					■	■

Figure 4
Village Sanitation Programme: Phase II

ACTIVITY	DEC	JAN	FEB	MAR	APR	MAY
1. DISTRICT PLANNING COMMITTEE MEETS	●	●	●	●	●	
2. PLANNING TEAM VISITS VILLAGES		●				
3. PREPARE TENDERS FOR SLABS, VENT PIPES AND SEAT INSERTS						
4. AWARD TENDERS						
5. MANUFACTURE SLABS, VENTPIPES AND SEAT INSERTS						
6. DELIVER SLABS, VENTPIPES AND SEAT INSERTS TO VILLAGES						
7. MONITOR/EVALUATE PREVIOUS VILLAGE SANITATION PROGRAMMES						
8. HIRE/TRAIN DISTRICT SANITATION FOREMEN FOR SECOND CLUSTER OF VILLAGES						

Figure 5
Village Sanitation Programme: Phase III

ACTIVITY	JUN	JUL	AUG	SEP	OCT	NOV
1. MEET WITH VDC/VET	●			●		
2. DISTRIBUTE HANDOUT A	●					
3. KGOTLA MEETING – DISTRIBUTE HANDOUT C	●					
4. DEADLINE FOR FIRST HALF-PAYMENT		●				
5. DEADLINE FOR FINAL PAYMENT				●		
6. DELIVER SLABS TO HOUSEHOLDS		■				
7. VSAs INSTALL RINGBEAMS		■	■			
8. HOUSEHOLDERS DIG PITS		■	■	■		
9. VSAs PLACE SLABS AND BUILD FOUNDATION			■	■	■	
10. HOUSEHOLDERS BUILD SUPERSTRUCTURES				■	■	■
11. DELIVER VENTPIPES AND SEAT INSERTS				■	■	
12. VSAs INSTALL VENTPIPES AND SEATS					■	■

Figure 6
Programme Organization Chart

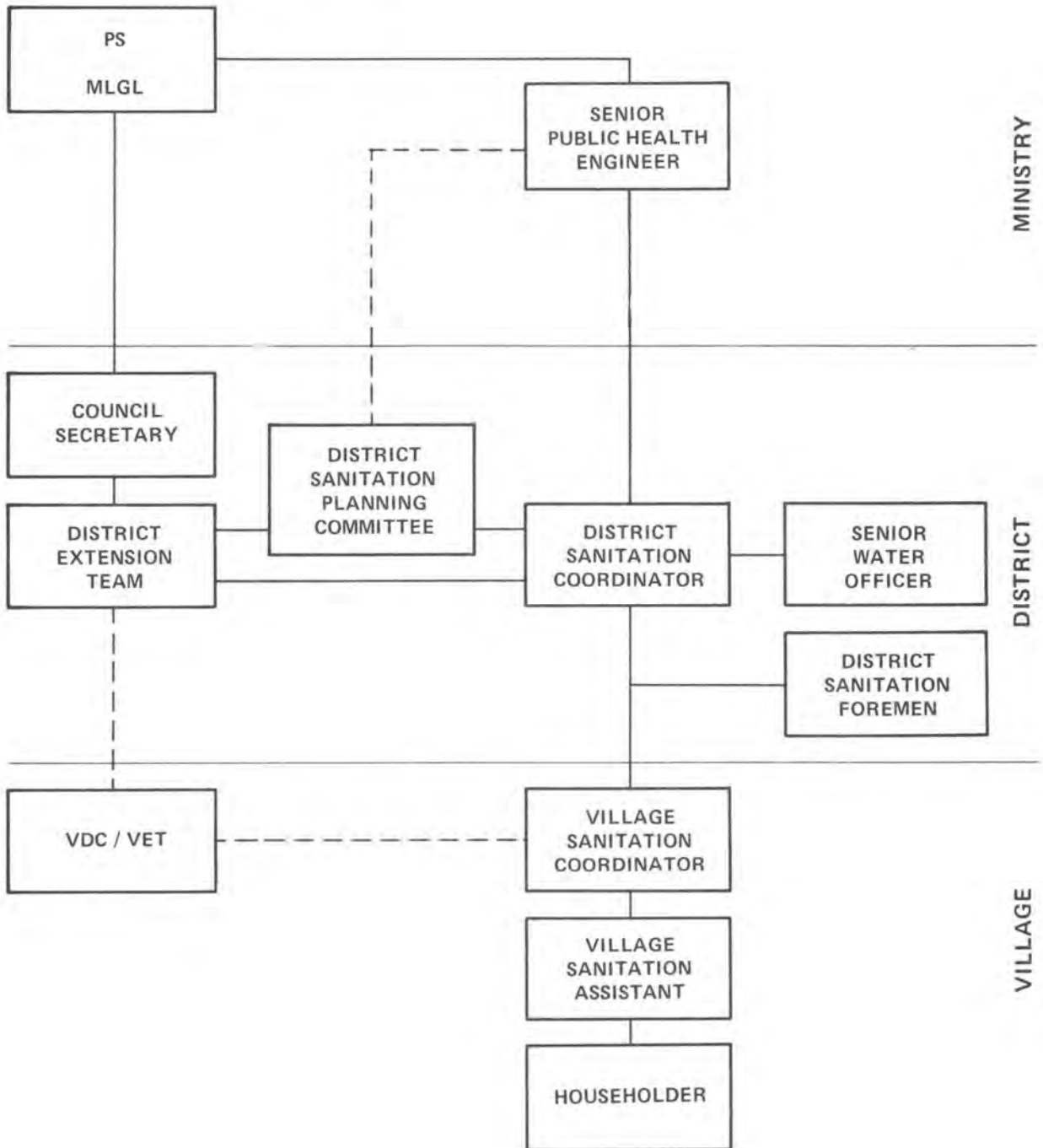

Figure 7
Plan and Elevations of Circular Brick

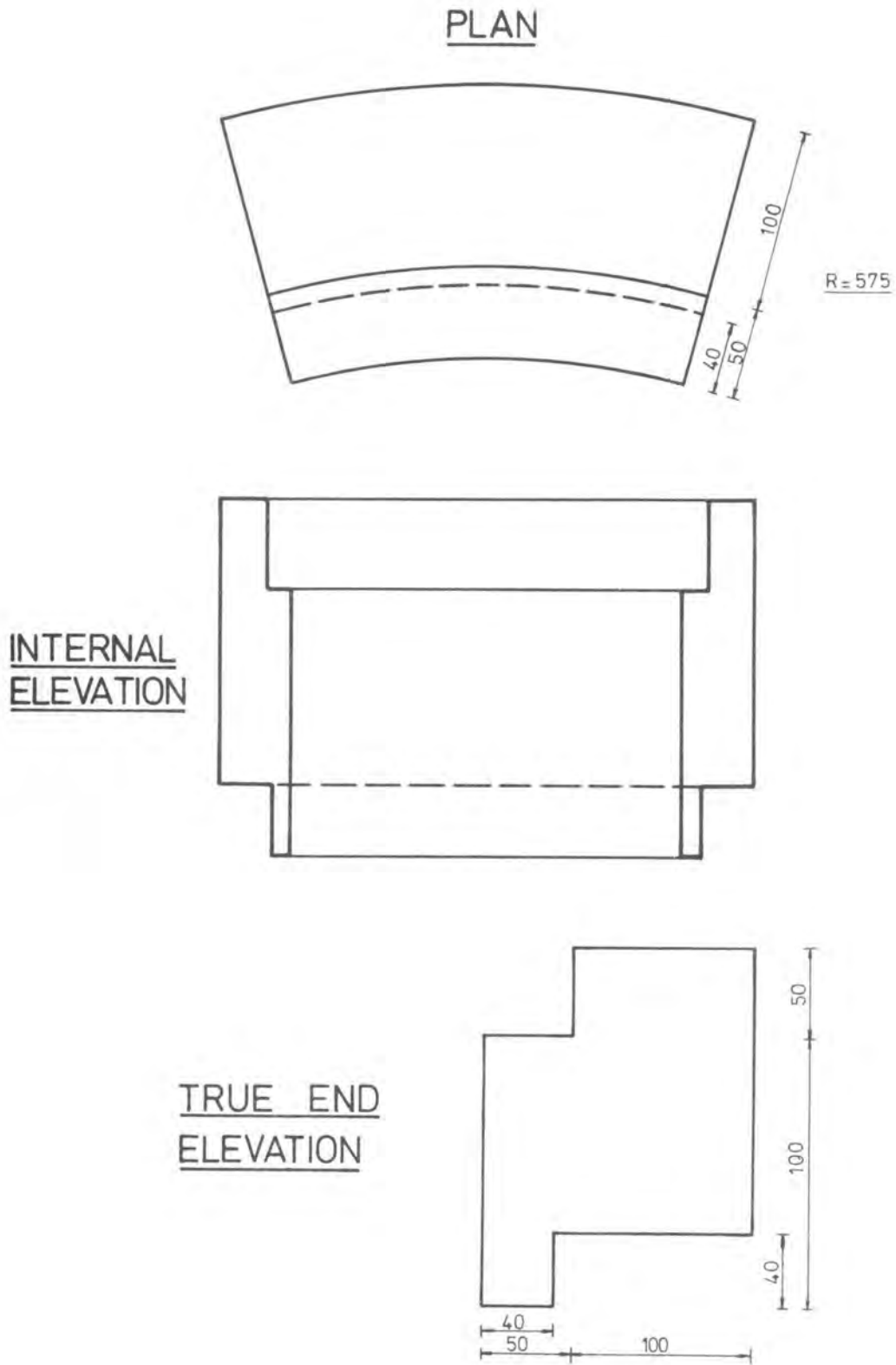

Figure 8

ESPP Trapezoidal Brick
(for latrine lining in sandy soil)

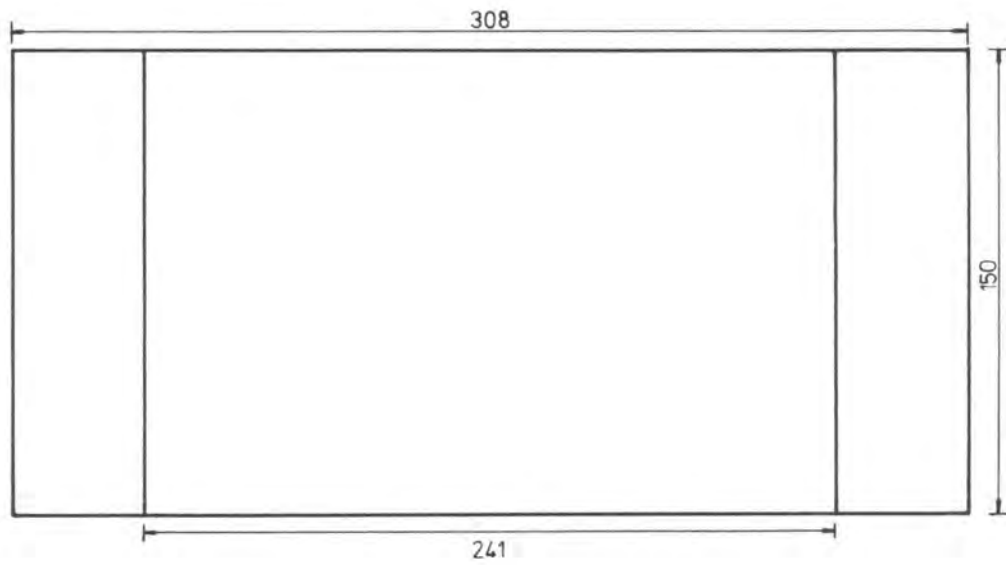
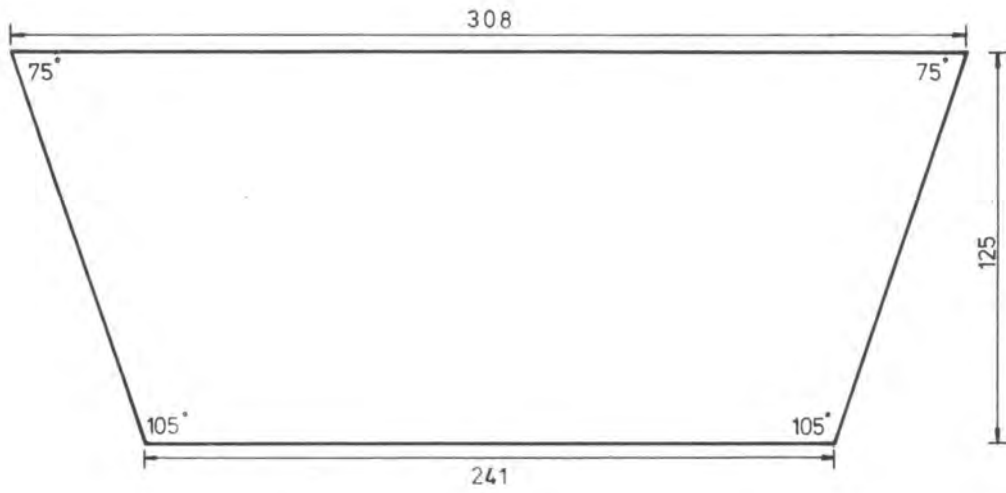

Figure 9
Trapezoidal Brick Supported on Small Piling

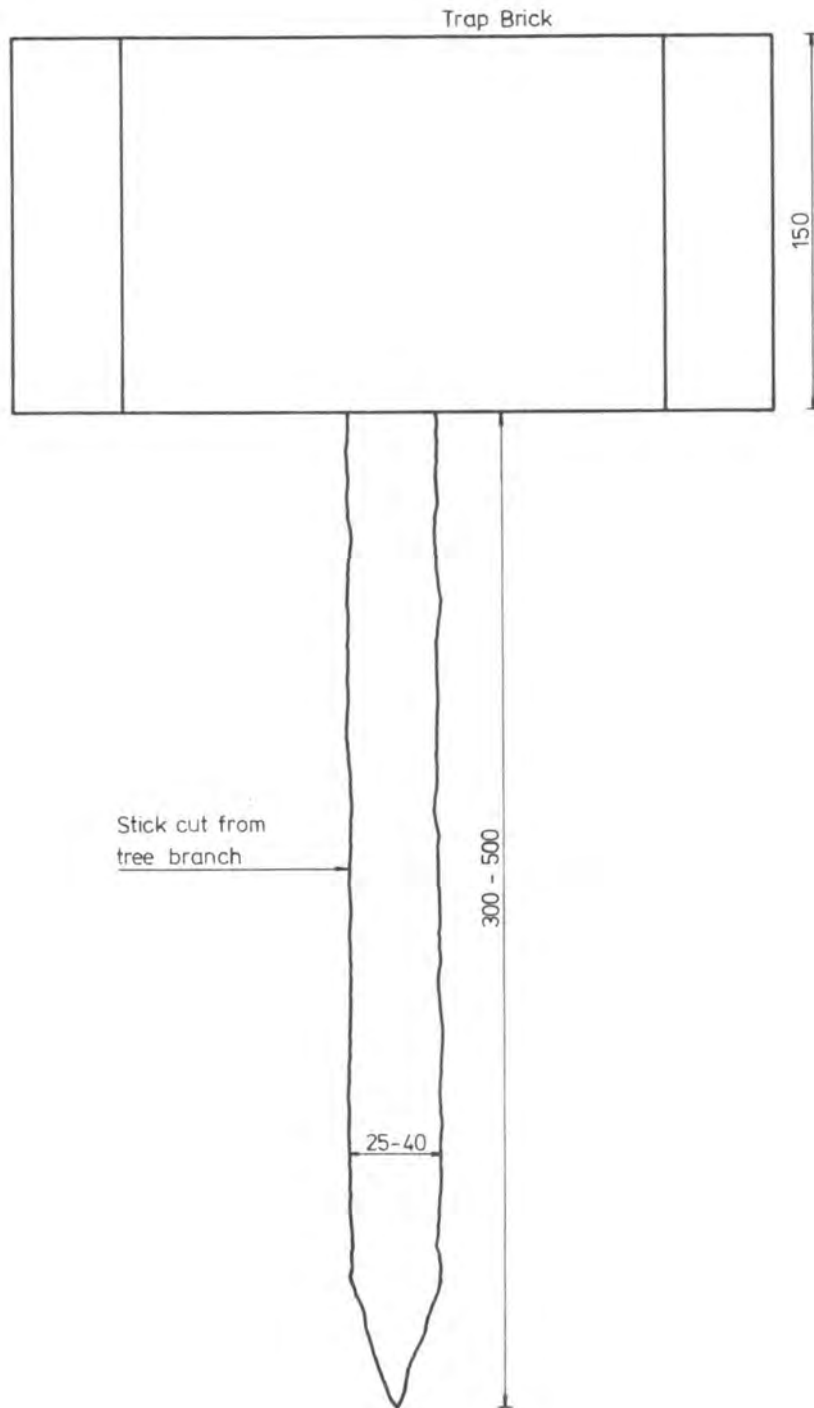

Figure 10
Trapezoidal Brick Pit

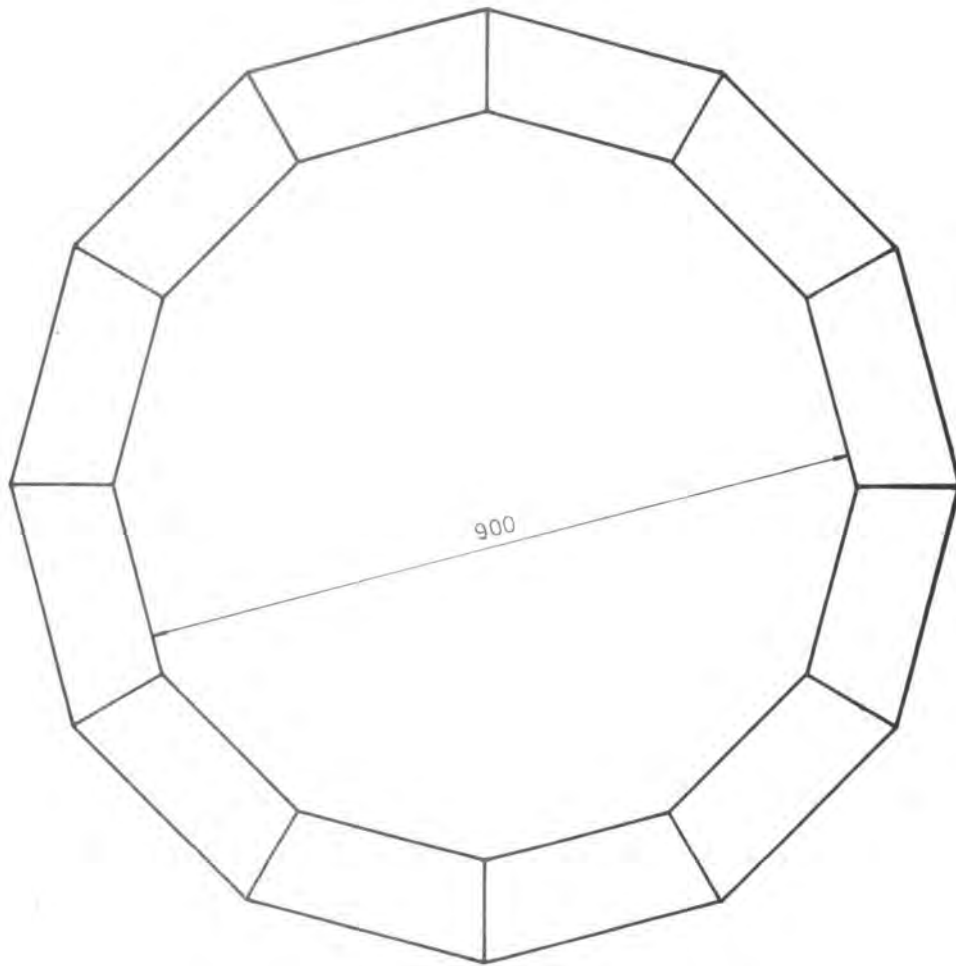
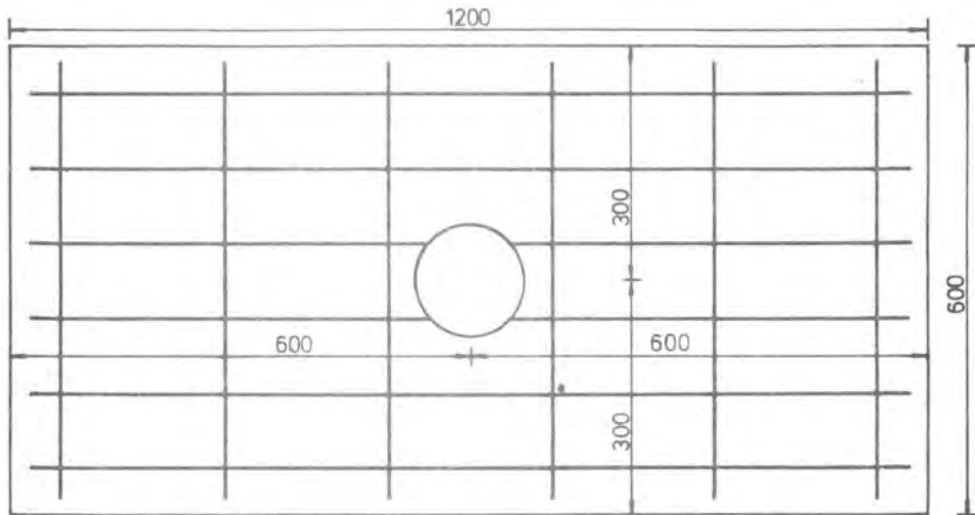
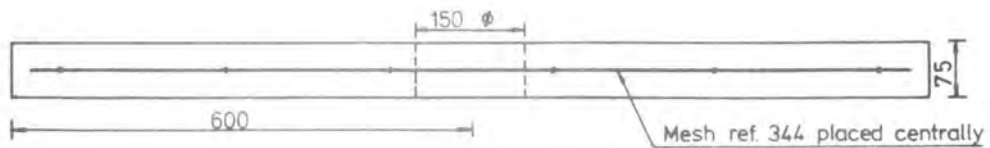

Figure 11
ESPP Rectangular Slab



SLAB A



NOTES:

1. All slabs to have min. 25mm cover.
2. Concrete to be min. 20 MPa.

SLAB B same but without central hole

Figure 12
ESPP Circular Slab

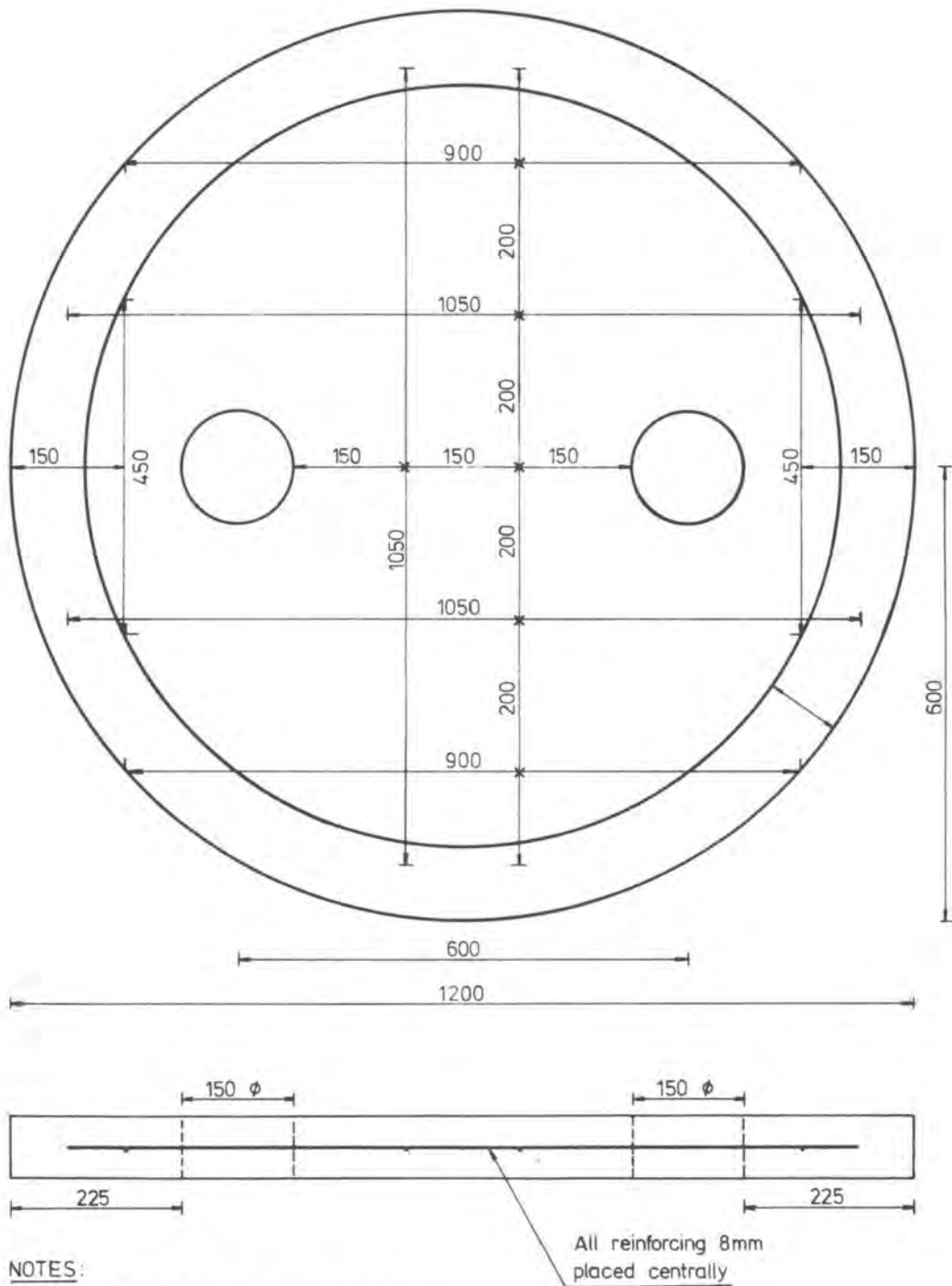
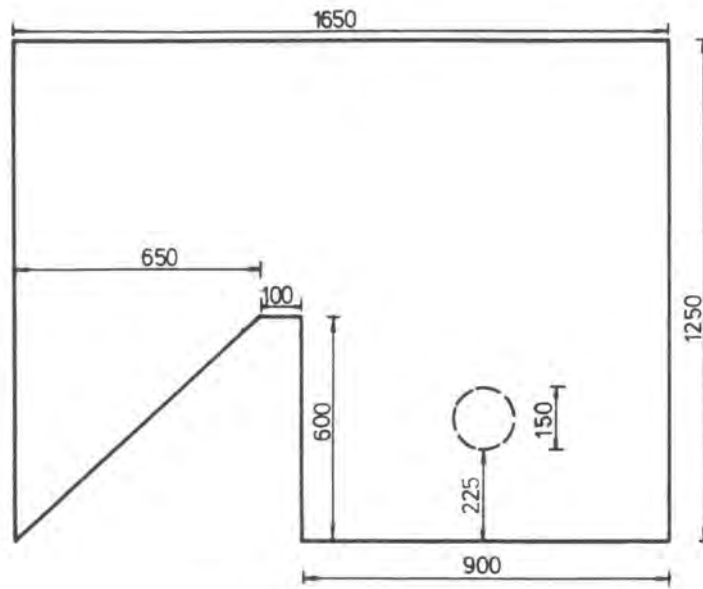
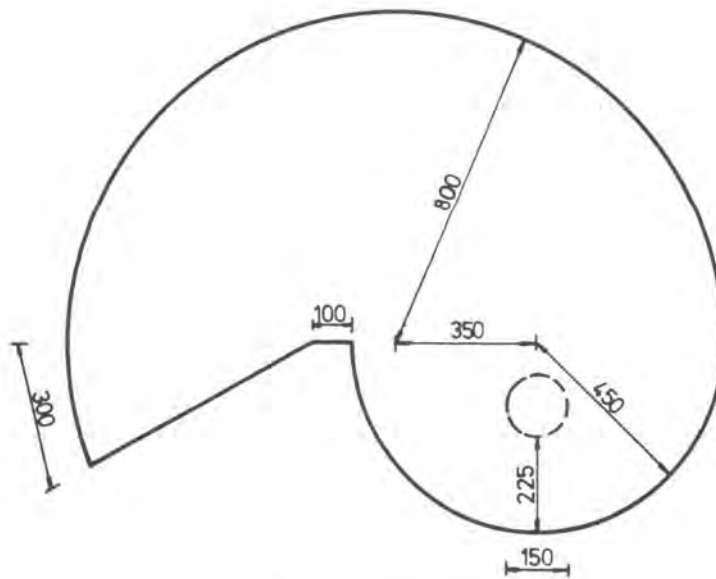

Figure 13
Circular and Rectangular Superstructure Wall Patterns



Rectangular Wall Pattern



Circular Wall Pattern

Figure 14
BOTVIP Latrine Type A1 — Plan

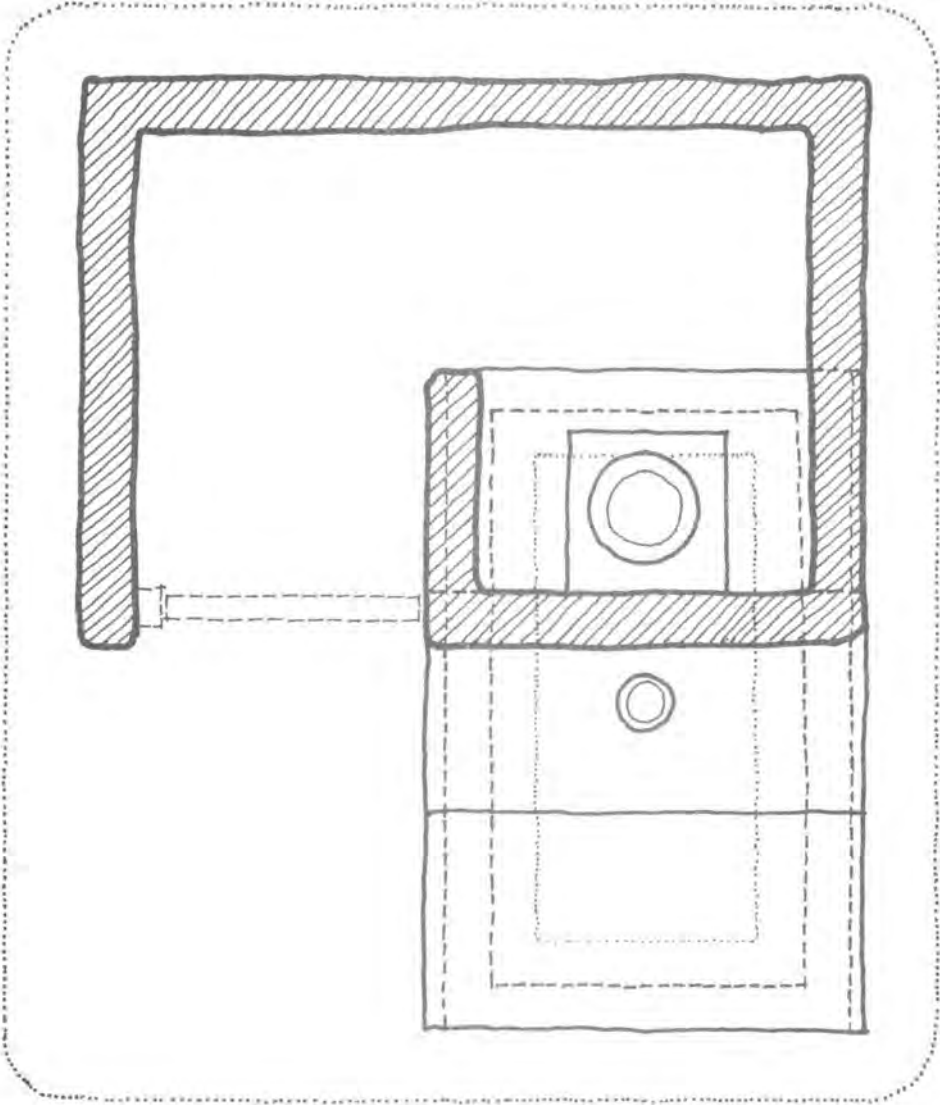

Figure 14 (cont'd)

BOTVIP Latrine Type A1 — Section

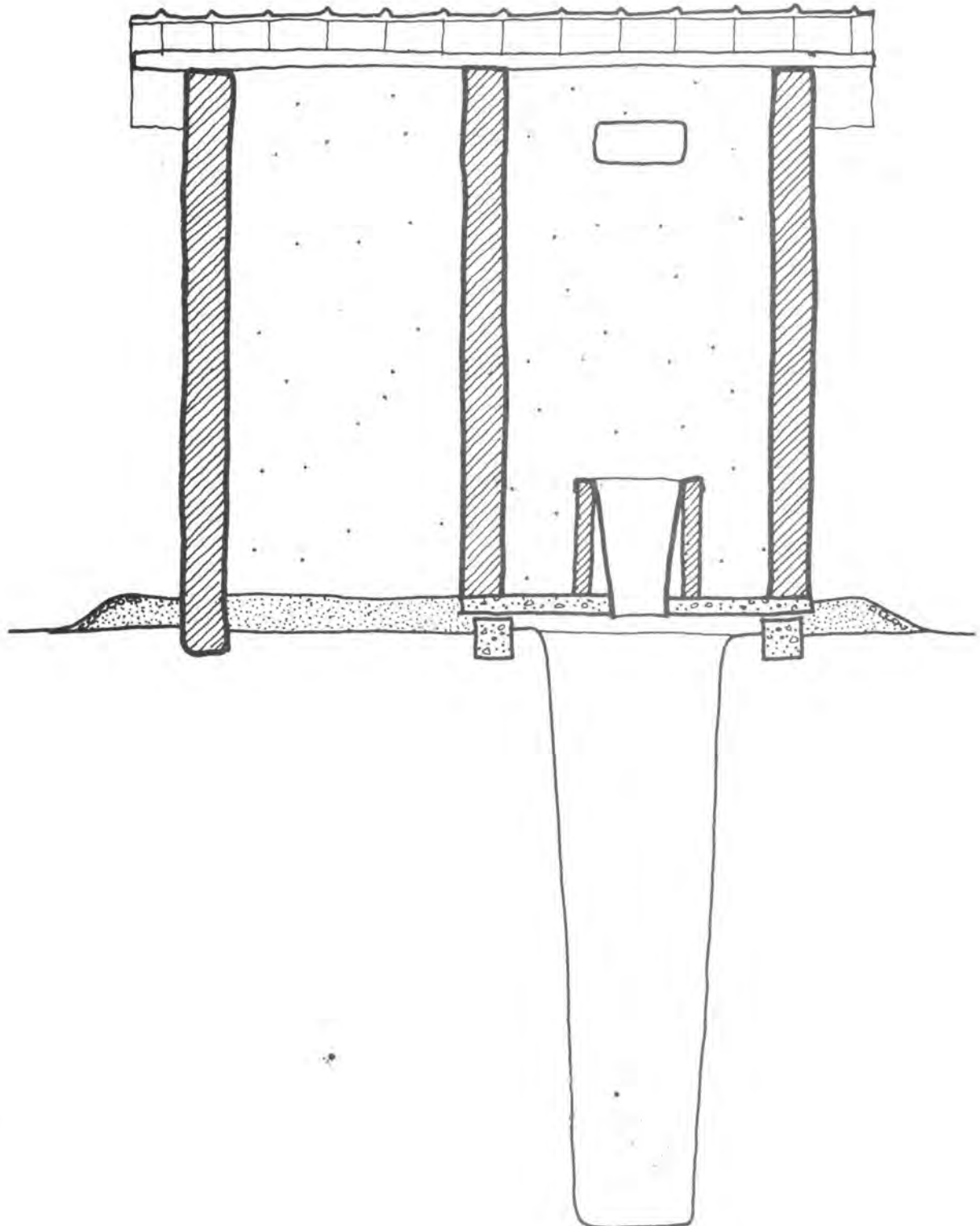

Figure 15
BOTVIP Latrine Type A2 — Plan

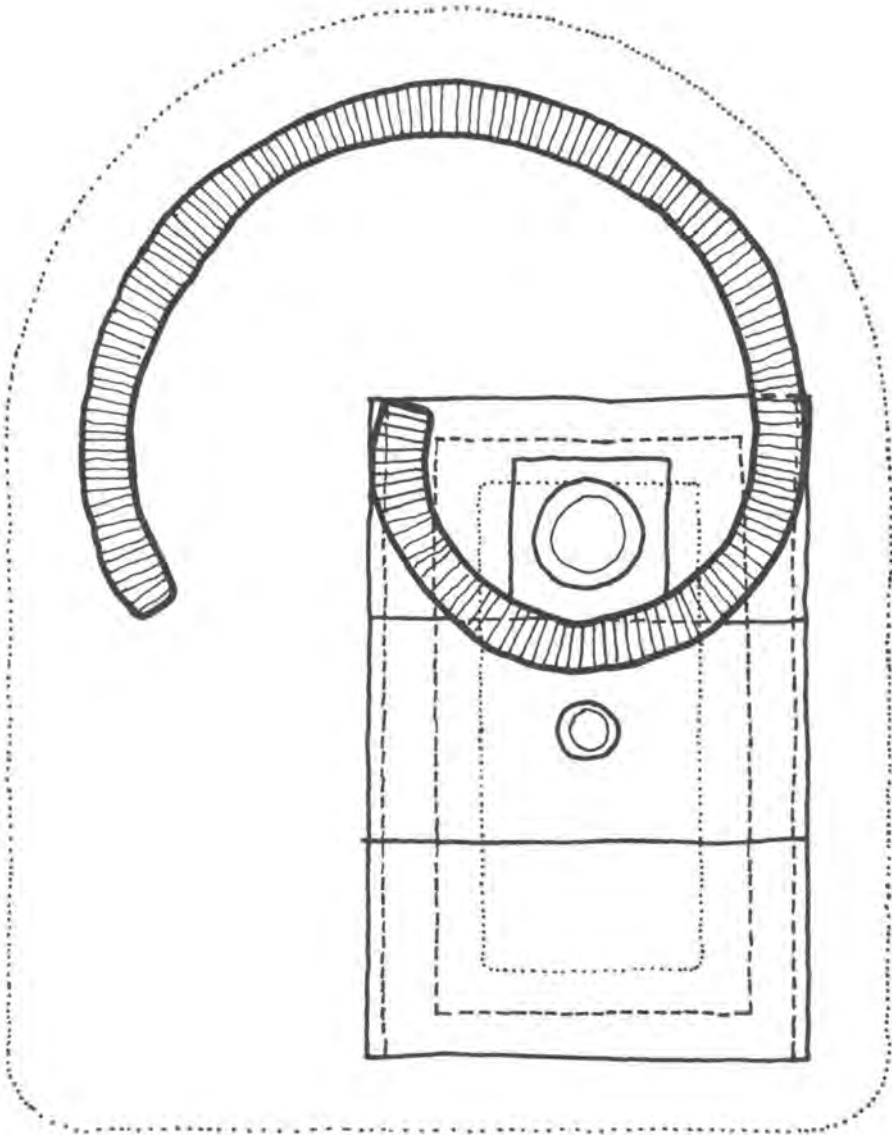

Figure 16
BOTVIP Latrine Type B1 — Plan

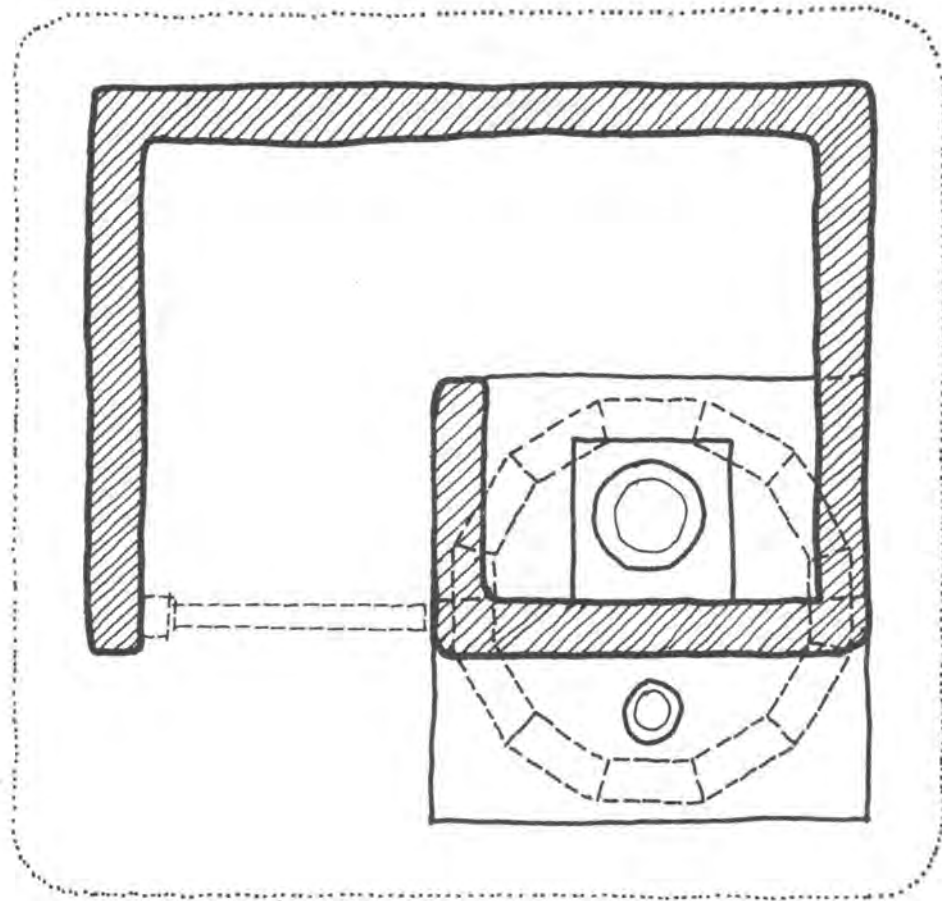

Figure 17
BOTVIP Latrine Type B2 — Plan

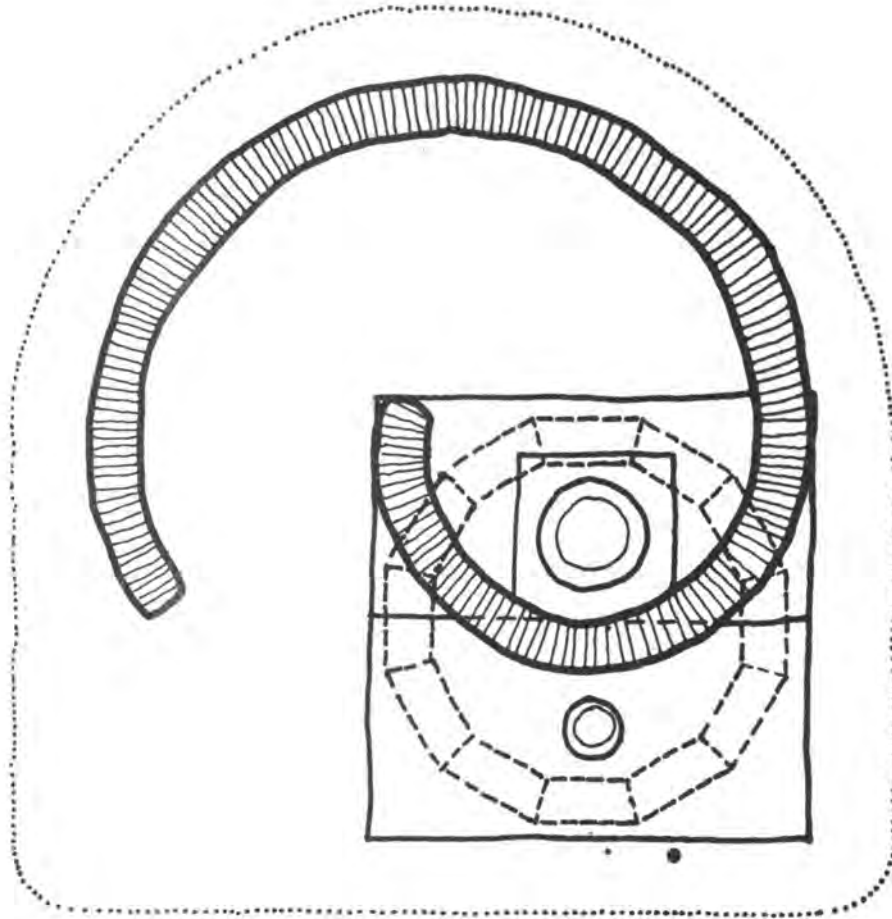

Figure 17 (cont'd)
BOTVIP Latrine Type B2 — Section

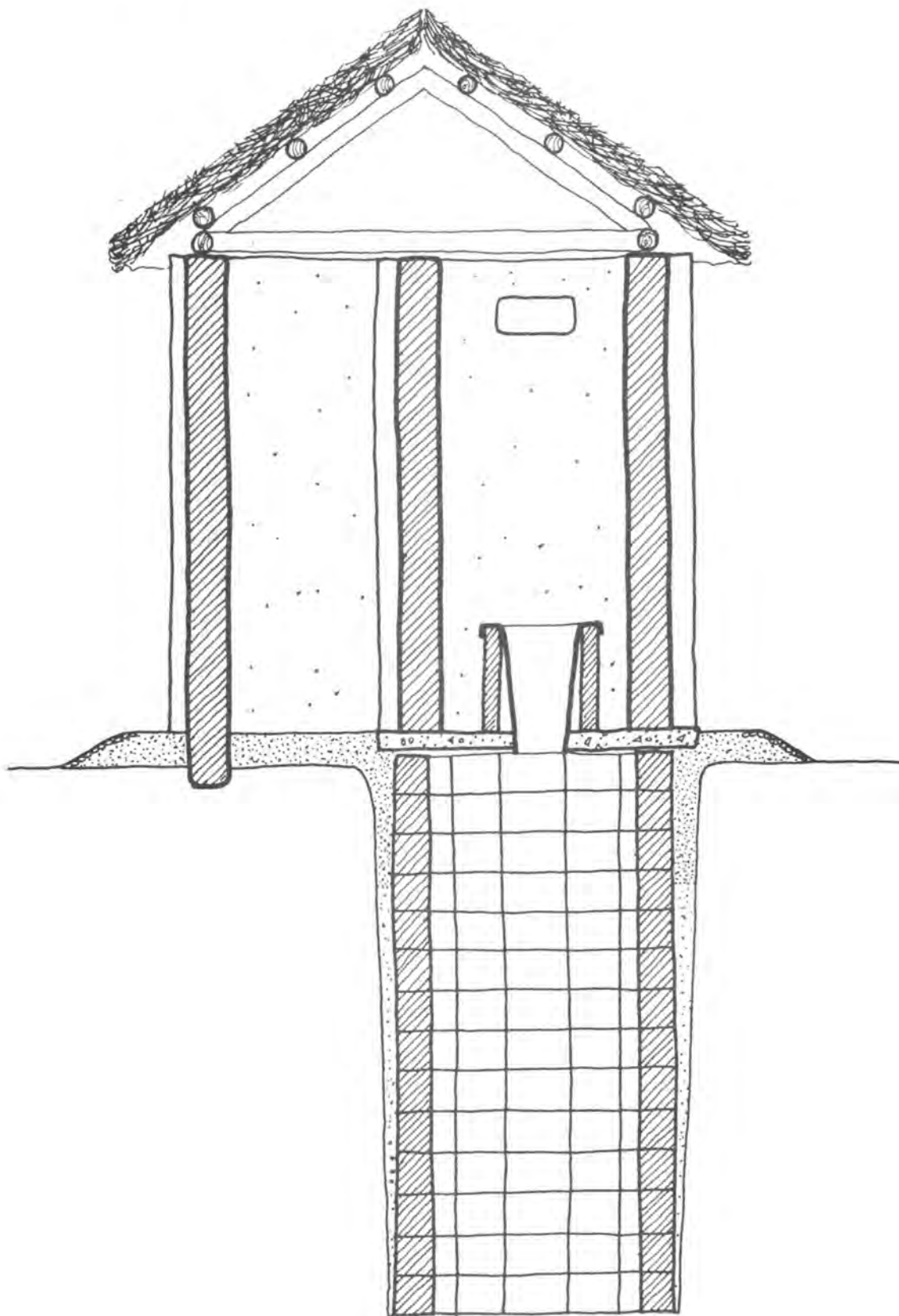

Figure 18
BOTVIP Seat Insert — Plan and Section

