



E-ASIA
university of oregon libraries

<http://e-asia.uoregon.edu>

U
15
0635
no. 31
c. 3

SPECIAL SERIES NO. 31

1 JUNE 1945

49-29843

461 (MIS SS) (1)

RECEIVED
LIBRARY
ARMY WAR COLLEGE
PERIODICALS SECTION
GUIDE
AUG 14 1952
TO MAPS
OF THE
FAR EAST
UNCLASSIFIED



MILITARY INTELLIGENCE DIVISION

U.S. WAR DEPARTMENT - WASHINGTON D.C.

in *on sheet*

UNCLASSIFIED

REGRADED _____ BY AUTHORITY

OF E.O. 10501

BY RAVIER ON 14 Aug 87

**GUIDE
TO MAPS
OF THE
FAR EAST**

LIBRARY
US ARMY WAR COLLEGE
CARLISLE BARRACKS, PA.

MILITARY INTELLIGENCE DIVISION
War Department • Washington, D. C.

PROPERTY OF US ARMY
UNCLASSIFIED

U
15
U635
no. 31
c. 3

8763

OCLC # 5066462

RESTRICTED

MILITARY INTELLIGENCE
SERVICE
WAR DEPARTMENT
WASHINGTON 25, D. C.

SPECIAL SERIES
NO. 31
MID. 461

Notice

1. *Special Series* is published for the purpose of providing officers with reasonably confirmed information from official and other reliable sources.
2. Reproduction within the military service is encouraged provided that (1) the source is stated, (2) the classification is maintained, and (3) one copy of the publication in which the material is reproduced is forwarded to the Military Intelligence Service, War Department, Washington 25, D. C.
3. This publication is based on material prepared by the Military Training Center, Camp Ritchie, Md., and other intelligence agencies.

DISTRIBUTION:

AAF (15); AGF (35); ASF (2); T of Opns (200); Island Comds (5); Base Comds (5); Depts (5); Arm & Sv Bd (5); Def Comd (5); Tech Sv (5); except QMG (35), CWS (10); SvC (5); HD (5); PC & S (1); SEPE (100); HRPE (3); Repl Dep (35); Gen & Sp Sv Sch (50); USMA (100); ROTC (3); UTC (50); RTC (75) except RTC 7 (250); Ord Dist (5); A (15); CHQ (15); D (6); B (10); R (4); W (6); G (4).

Refer to FM 21-6 for explanation of distribution formula.

CONTENTS

	<i>Page</i>
SECTION I. INTRODUCTION TO FOREIGN MAPS	1
Classification	1
Map Analysis	2
SECTION II. BRITISH MILITARY MAPS OF THE FAR EAST	6
Introduction	6
British Maps of Foreign Countries.....	6
British Coordinate System.....	10
SECTION III. JAPANESE TOPOGRAPHIC MAPS	16
Introduction	16
Military Map Series of Japan.....	16
Japanese Coordinate Systems.....	17
Characteristics of Japanese Topographic Maps.....	18
Japanese Characters	20
Glossary of Japanese Map Expressions.....	24
SECTION IV. CHINESE MILITARY MAPS	29
Introduction	29
Military Maps of China.....	29
Chinese Coordinate Systems.....	29
Characteristics of Chinese Military Maps.....	30
Chinese Characters	32
Glossary of Chinese Map Expressions.....	34
SECTION V. MISCELLANEOUS MILITARY MAPS OF THE FAR EAST	39
Burma, India, and Malaya	39
French Indo-China	39
Netherlands East Indies.....	39
Types and Revisions.....	40
APPENDIX	47
Chinese System of Linear Measure.....	47
Equivalent Units of Angular Measure.....	47
Conversion Factors	47
Prime Meridians used on Foreign Maps with Longitudinal Distances from Greenwich	48
Legends	48
British Maps of the Netherlands East Indies.....	50
Glossary of Map Terms.....	51
Bibliography	57

ILLUSTRATIONS

<i>Figure</i>	<i>Page</i>
1. Legend translation	6
2. Grid data	7
3. Grid data	7
4. Grid reference box	7
5. Incidence of grid letters and index to adjoining sheets from France and Belgium Series, 1:50,000, G. S. G. S. 4040, Sheet 61	8
6. Glossary of foreign terms and abbreviations from Java and Madura Series, 1:50,000, G. S. G. S. 4202, Sheet 51/XLIII-C and 51/XLIV-A	8
7. Graphic scales in miles and yards	8
8. Index to adjoining sheets from French North Africa Series, 1:500,000, G. S. G. S. 4175	9
9. Declination diagram from France and Belgium Series, 1:50,000, G. S. G. S. 4040, Sheet 61	9
10. Reliability diagram	9
11. Section of map with Modified British Grid from France and Belgium Series, 1:50,000, G. S. G. S. 4040, Sheet 61	13
12. Diagram of 50-kilometer square of the British Grid System	15
13. Diagram showing approximate positions of various items of marginal information on Japanese maps	19
14. Contours used on Chinese maps	30
15. Diagram showing position of marginal information on Chinese maps	31
16. Section of Chinese map, 1:50,000	32
<i>Plates</i>	<i>Page</i>
I. Diagram of British Grid Zones	11
II. Diagram of the lettering system of the Modified British Grid	12
III. Section of map from original Japanese Series, 1:50,000, Sheet 12	27
IV. Section of map from Kyushu Series, 1:50,000, AMS L772, Sheet 133	28
V. Section of map from China Series, 1:100,000	37
VI. Section of map from China Series, 1:50,000	38
VII. Section of map from Burma and Thailand Series, 1:253,440 Provisional G. S. G. S. 4218, Sheet F-47D	43
VIII. Section of map from Burma Series, 1:126,720, Sheet 92G/SW	44
IX. Section of map from Indo-China Series, 1:100,000, HIND, Sheet No. 137 (East)	45
X. Section of map from Java and Madura Series, 1:50,000, G. S. G. S. 4202, Sheet 51/XLIII-C and 51/XLIV-A	46

RESTRICTED

SECTION I

INTRODUCTION TO FOREIGN MAPS

Although most of the maps that are issued to the armed forces of the United States for use in military operations throughout the Far East will be produced by map-making agencies of the United States, there will be occasions when it will be necessary to make use of maps published by the mapping agencies of the foreign countries concerned.

It is highly desirable that military personnel acquire a sufficient working knowledge of certain maps published by foreign countries, to enable reading and use of such foreign maps for planning and intelligence purposes. Consequently, it is the purpose here to discuss briefly the major characteristics of foreign maps in order to assist those who use them.

CLASSIFICATION

Military maps

Military maps may be classified according to their method of production, viz., original surveys, compilations, and copies. An *original survey* is a map drawn directly from data obtained by actual ground surveys. A *compilation* is a map made from existing maps, aerial photographs, new surveys, reconnaissance, and intelligence reports. A *copy* is a map reproduced in its original form, usually supplemented by a military grid and additional marginal information. The maps prepared by mapping agencies of the United States, for the most part, will be the *compilation* type, that is, compiled from maps published by a foreign country, with place names and marginal data transliterated into English, or compiled by aerial photogrammetric methods.

Projections

Map projections (see Glossary) are of extreme importance to cartographers, military surveyors, artillerymen, navigators, and others who compute and use various grid tables and trigonometric calculations. However, most military personnel in the field need not be concerned with the intricacies of this complex subject, since a knowledge of it is not necessary when using ordinary point designation methods or for obtaining practical terrain intelligence from United States or foreign maps.

MAP ANALYSIS

The interpretation of foreign maps is materially aided if a methodical outline of analysis is followed. A systematic approach will outline pertinent information in an orderly manner, thus obviating the loss of such information in a mass of interesting but disorganized detail. A suggested outline of analysis consists of six steps: evaluation and orientation, scale, coordinate systems, declination, relief, and conventional signs.

Evaluation and Orientation

The evaluation and orientation of a map will provide answers to the questions: "How up to date and how accurate is the map?" and "What geographical area does the map cover?" The date of the map, the publishing agency, the manner in which it was made, and the source of its information are indications of the map's accuracy and reliability. Certain items of marginal information may provide a means of orienting a map in its approximate geographic position on the face of the earth.

The *date of survey* indicates the time the essential data was obtained by actual ground survey.

The *date of revision* is the most definite evidence of a map's "up to date-ness", providing that the extent of the revision is known. Even though land forms change slowly, a map prepared in the nineteenth century may not give a true picture of the terrain because early survey methods were crude, and the finished map usually was inaccurate. More recent surveys are of a higher order of accuracy. Cultural features (works of man), exemplified by road net works and highly industrialized areas, are particularly subject to modification.

The *date of compilation* indicates the time at which data from appropriate available sources went into the making of a new map, but provides no indication as to the "up to dateness" of the information found on that map. However, the date of the sources from which the map is compiled may be helpful.

The *date of copy* refers to the time a map was reproduced in its original form and amplified by additional data. It does not necessarily indicate that a map is up to date.

The *date of publication* is the date most commonly found on maps. It indicates only the time at which a map, and therefore, the information on it, was made available for general use.

The *date of reprint* refers to the time at which a set of maps was printed from previously used plates. This date does not signify that changes have been made on the map.

The *type of agency* responsible for the preparation of a map is an indication of its accuracy. Maps published by governmental or military agencies are generally the most accurate. However, the standards of these agencies vary. On the other hand, some civilian agencies produce accurate maps, but fre-

quently are concerned only with maps of a general nature; that is, some maps produced for civilian use may not contain the specific detail necessary for military purposes.

The *composition* of a map is an indication of its reliability. The proper placing of place names and symbols, the detail in which a coast line is represented, the careful use of color, and other items of draftsmanship indicate the care with which a map has been prepared, but are not necessarily proof of the accuracy of the information shown.

Marginal information usually provides a means of orienting a map geographically, besides indicating its "up to dateness" and accuracy. The names of sheets adjacent to a map may be indicated in the centers of the four margins of that map, or in a small marginal diagram. The diagram may also include political boundaries to aid further in geographical orientation.

Scales

Many foreign maps are published on the same scales as United States maps. The scales commonly found on both United States and foreign maps are 1:200,000, 1:100,000, 1:50,000, and 1:25,000. These scales permit map distances to be converted quickly and easily into ground distances. Most foreign countries use the metric system of measurement. For example, 1 centimeter on a map of 1:100,000 scale represents 1 kilometer on the ground. Similarly, 1 centimeter represents $\frac{1}{2}$ kilometer on a 1:50,000 map or $\frac{1}{4}$ kilometer on a map of 1:25,000 scale. For conversion to yards and miles see the conversion tables in the appendix.

Map distances on 1:253,440 and 1:63,360 scales are readily converted into ground distances in the English system of measurement, for example, 1 inch equals 4 miles and 1 mile, respectively, on maps of these scales.

Troops operating in foreign countries should have complete command of the metric system and be able to convert without difficulty from the metric system into the English system, and vice versa. Conversion graphs are printed on the newest editions of some Army Map Service series for convenience in changing distances and altitudes from one system to the other.

Coordinate system(s)

A consideration of the coordinate system (s) used on a map constitutes the third step of the map analysis. Geographic coordinates are basically the same on all maps. Longitude is measured east and west from a prime meridian (see Glossary), and latitude is measured north and south from the equator.

The *degree system (sexagesimal system)* is in almost universal use. The principal variation on foreign maps is the use of prime meridians other than that of Greenwich. The prime meridian usually passes through the principal city of the country.

Each nation has its own *military grid system*. Foreign countries employ the metric system of measurement in their grid systems almost exclusively.

Declination

Declinations on foreign maps are usually indicated in a manner similar to that used on United States maps. The usual abbreviations and symbols for the three norths and for declinations are not always present and are sometimes different from those found on United States maps.

True north, if not indicated in the margin, can be determined from meridians of longitude, while grid north can be determined from the military grid. Magnetic declination may be printed on a map, and magnetic north may be indicated by a diagram in the margin. The incidence of arrows in the diagram must not be construed as being exact, since the sketch may be diagrammatic.

Declination protractors are used on a few foreign maps. The declination protractor is a device printed on the face of a map enabling one to draw a magnetic north line across that map.

Each ground map on 1:250,000 and larger scales now published by the Army Map Service, United States War Department, has a declination protractor for use in plotting the magnetic north line across such maps. Foreign protractors are generally similar to the United States protractor, which consists of a pivot point (P) at the bottom and a horizontal degree scale at the top of the map. Thus a line drawn between the "P" point at the bottom of the map and the value of the G-M angle (see Glossary) plotted on the degree scale at the top of the map represents the direction of magnetic north in the area covered by the map. The magnetic north line so computed may be used for orienting the map by means of a compass and for determining magnetic azimuths between points on the map.

Relief

Relief is represented in many ways on foreign maps. Contours, hachures, spot elevations, hill shading, and layer tints are used, either alone or in combination.

Contouring is the most common means of representing ground forms. Contour intervals are usually expressed in meters on foreign maps. More than one contour interval may be shown on a map. For example, 5-meter, 10-meter, and 20-meter intervals may be used, each being depicted by a different type of contour line. Form lines (see Glossary) often supplement contour lines.

Hachures are found on many maps. This system of representing relief shows clearly the direction and relative degree of slope, but does not accurately indicate elevations. Steep slopes are represented by relatively short hachures close together, while gentle slopes are shown by longer, thinner hachures. Several countries have endeavored to develop a method of hachuring that will

provide a more definite means of determining slope, though these efforts have not proved entirely successful.

Spot elevations are used to supplement other methods of representing relief and are rarely used alone.

Hill shading (see Glossary), is another method of representing relief. It may be used to supplement hachuring and contouring. It assists in giving a clearer picture of topography and is used primarily on sheets covering very hilly or mountainous territory.

Layer tints or *altitude tints* (see Glossary) indicate elevations above sea level by use of color intensities. This method is sometimes used in conjunction with contouring to accentuate differences in elevation.

Conventional signs

Conventional signs on maps published by one country differ from those on maps of other countries. Although the symbol for a particular object may vary on maps of different countries, and on different map series of the same country, it should be observed that these symbols possess a basic similarity. Conventional signs are intended to represent, as pictorially as possible, the actual appearance of terrain features and of objects on the ground.

SECTION II

BRITISH MILITARY MAPS OF THE FAR EAST

INTRODUCTION

The *Directorate of Military Surveys (Dsvy)*, formerly the *Geographical Section, General Staff (G. S. G. S.)* of the British War Office (W. O.) is the agency of the British Government which establishes the policies of British map reproduction. The mechanical processes of map-making are performed by the *Ordnance Survey (O. S.)*

BRITISH MAPS OF FOREIGN COUNTRIES

Since 1940 the policy of the *Geographical Section of the General Staff*, in regard to maps of foreign countries, has been to utilize existing maps of these countries in the making of British maps. In carrying out this policy, it has been necessary to make numerous additions to the original maps. First editions published by G. S. G. S. are frequently identical with the original, if material for revision is not at hand. Subsequent editions are revised to include information as it becomes available.

The reading of foreign maps is facilitated by the addition of the following features: legend translation; British grid and accompanying data; glossary of foreign terms and abbreviations; graphic scales in miles and yards; index to adjoining sheets; declination diagrams; reliability diagram.

REFERENCE













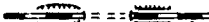

Railway, normal gauge (double track)	
Railway, normal gauge (single track)	
Railway, normal gauge (under construction)	
Railway, narrow gauge 0.76 metres	
Cutting, tunnel, embankment	
Railway stations, halts	
Tramway line	
Cable railway	
Principal roads	
Minor roads	
Cart roads, Cart tracks	
Bridle Path, Footpath	
Bridge; Iron, stone, wood	
International boundary	
Post office, Telegraph office	
Wireless station; transmission, receiving	
Church or monastery with one or more towers	
Mosque with one or more minarets	
Synagogue, Chapel, Calvary, Monument	

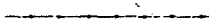
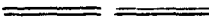
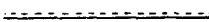
Figure 1. Legend translation.

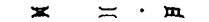
Legend translation

The legend translation gives the most common conventional signs used on the map. The foreign terms for the features represented are often included. Revisions of maps may have the British system of road classification overprinted on the foreign road symbols.

British grid

The British grid of the area covered by the foreign map is printed on the British edition. *Accompanying data* may include: grid data, grid reference box, and the incidence of grid letters.

Grid data, in the distinctive color of the grid, is printed in the margin of the map.

GRID DATA	
Southern Italy Grid	
Colour.....	Blue
Projection.....	Lambert Conical Orthomorphic
Spheroid.....	Bessel
Origin.....	39° 30' N. 14° E. of Greenwich
False Co-ordinates of origin.....	700,000 metres E. 600,000 metres N.

Figure 2. Grid data.

The Grid on this map is Nord de Guerre Zone. Origin- the intersection of the parallel 55 Grades North
with the longitude 6 Grades East of Paris Observatory. Longitude of Paris is 2°20' 14" East of Greenwich.

HEIGHTS IN METRES

Figure 3. Grid data.

A *grid reference box* explains briefly how to read the British grid.

TO GIVE A GRID REFERENCE ON THIS SHEET			
Use only LARGER Grid figures viz..... 280000			
POINT	OLIG		
LETTER	From face of map	L
EASTINGS.			
Take figure of West edge of small square in which point lies.....		29	
Estimate tenths eastwards.....		8	
		298	
NORTHINGS.			
Take figure of South edge of small square in which point lies.....		00	
Estimate tenths northwards.....		7	
		007	
REFERENCE	L 29800	007
Unit: metre	Square	1000	Reference to nearest
			100
Nearest similar reference on this grid 500 Km distant			

Figure 4. Grid reference box.

The incidence of grid letters in the area covered by the map may be superimposed on an index to adjoining sheets.

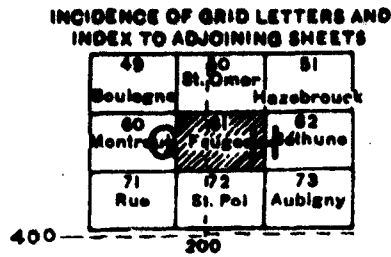

Figure 5. Incidence of grid letters and index to adjoining sheets from France and Belgium Series, 1:50,000, G. S. G. S. 4040, Sheet 61.

Glossary or foreign terms and abbreviations

The glossary of foreign terms and abbreviations consists of English translations of foreign words and abbreviations used on the map.

GLOSSARY

Alas.....	forest
Bgai.....	bay
Decauville.....	narrow gauge railroad
Djatibosch.....	teakwood forest
Gebergte.....	range
Genting.....	defile, narrows
Goea.....	cave
Goenoeng: G.....	mountain
Hilir.....	hinterland
Igir.....	hill
Kali: K.....	river
Lebak: L.....	river
Oedjoeng: O.....	point
Onderneming: Og.....	plantation
Palaboehan.....	bay, anchorage
Poelo: P.....	island
Rawa: R.....	swamp, marsh
Solo: S.....	river
Straat.....	strait
Tandjoeng: Tg.....	cape
Tji.....	stream
Wadoek: W.....	irrigation pond
Wildhoutbosch.....	jungle
Zee.....	sea

Figure 6. Glossary of foreign terms and abbreviations from Java and Madura Series, 1:50,000, G. S. G. S. 4202, Sheet 51/XLIII-C and 51/XLIV-A.

Graphic scales in miles and yards

Graphic scales in miles and yards are added to supplement the metric scales on foreign maps, since Britons and Americans are, generally speaking, unfamiliar with the metric system of measurement.

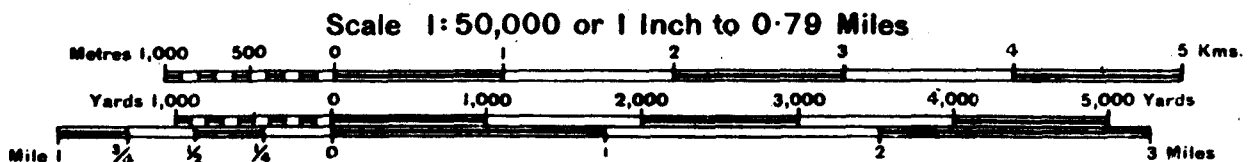

Figure 7. Graphic scales in miles and yards.

Index to adjoining sheets

The index to adjoining sheets indicates graphically the sheet name or sheet number, or both, and the relative position of the sheets adjoining the one on which the index appears. Not all foreign maps have such diagrams.

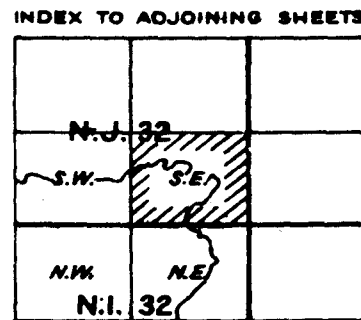

Figure 8. Index to adjoining sheets from French North Africa Series, 1:500,000, G. S. G. S. 4175.

Declination diagram

A declination diagram indicates grid declinations for the east and west edges of a sheet, and magnetic declination for the center. This information is lacking on some foreign maps. The term *convergence* (see Glossary) is frequently used in referring to grid declinations.

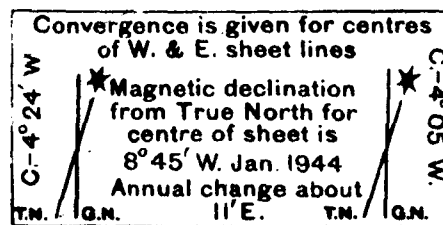

Figure 9. Declination diagram from France and Belgium Series, 1:50,000, G. S. G. S. 4040, Sheet 61.

Reliability diagram

A reliability diagram indicates the area of revision and the sources from which the map was revised.

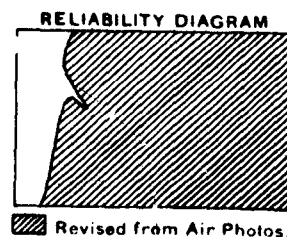

Figure 10. Reliability diagram.

The addition of the above information to British editions of foreign maps has provided an extensive map coverage of foreign countries which can readily be put to use by English-speaking troops. Other information may be found on G. S. G. S. editions, although those features discussed here are the most important in the interpretation of a foreign map.

BRITISH COORDINATE SYSTEMS

Two coordinate systems have been employed by British military mapping agencies, the *British Grid System* and the *Modified British Grid System*. The latter has been printed on maps published since 1927, while the British grid was placed on maps published prior to that time. Both systems of reference are basically the same. They differ only in small details.

Modified British Grid System

The Modified British Grid System has been used on maps published by the British since 1927. The system is found on some map series issued by the United States Army Map Service. British military grids are used on maps covering a large part of the Pacific and Asiatic theaters of operations. The Modified British Grid System permits the use of a military grid on a geographic area regardless of its size or shape. This is accomplished by dividing a major portion of the earth's surface into a number of grid zones designated according to their geographic locations, for example, South Italy Grid Zone, Northern European Zones I, II, and III, etc. (See plate I.)

Features of British military grids and zones

British military grids and zones are characterized by four features: (1) size and shape, (2) overlap area, (3) point of origin, and (4) color of grid covering the zone. These differ from the corresponding features of United States military grids and zones as established for the continental United States as follows:

(1) The size and shape of United States grid zones are defined, for example, each is 9° of longitude in width and extends roughly from the northern to the southern boundary of the United States. British grid zones do not have definite sizes and shapes, as shown in plate I.

(2) There is an overlap of 1° on each side of a United States grid zone. British grid zones do not overlap.

(3) The point of origin of a United States grid zone lies at the intersection of the central meridian of the zone and $40^{\circ}30'$ north latitude. The origin of a British grid zone, the true origin (see Glossary), is at the intersection of a specific meridian of longitude and a specific parallel of latitude located in the approximate center of the zone.

(4) The grid covering a United States grid zone is usually printed in black. Every British grid zone is given a distinctive grid color. Grid lines, their

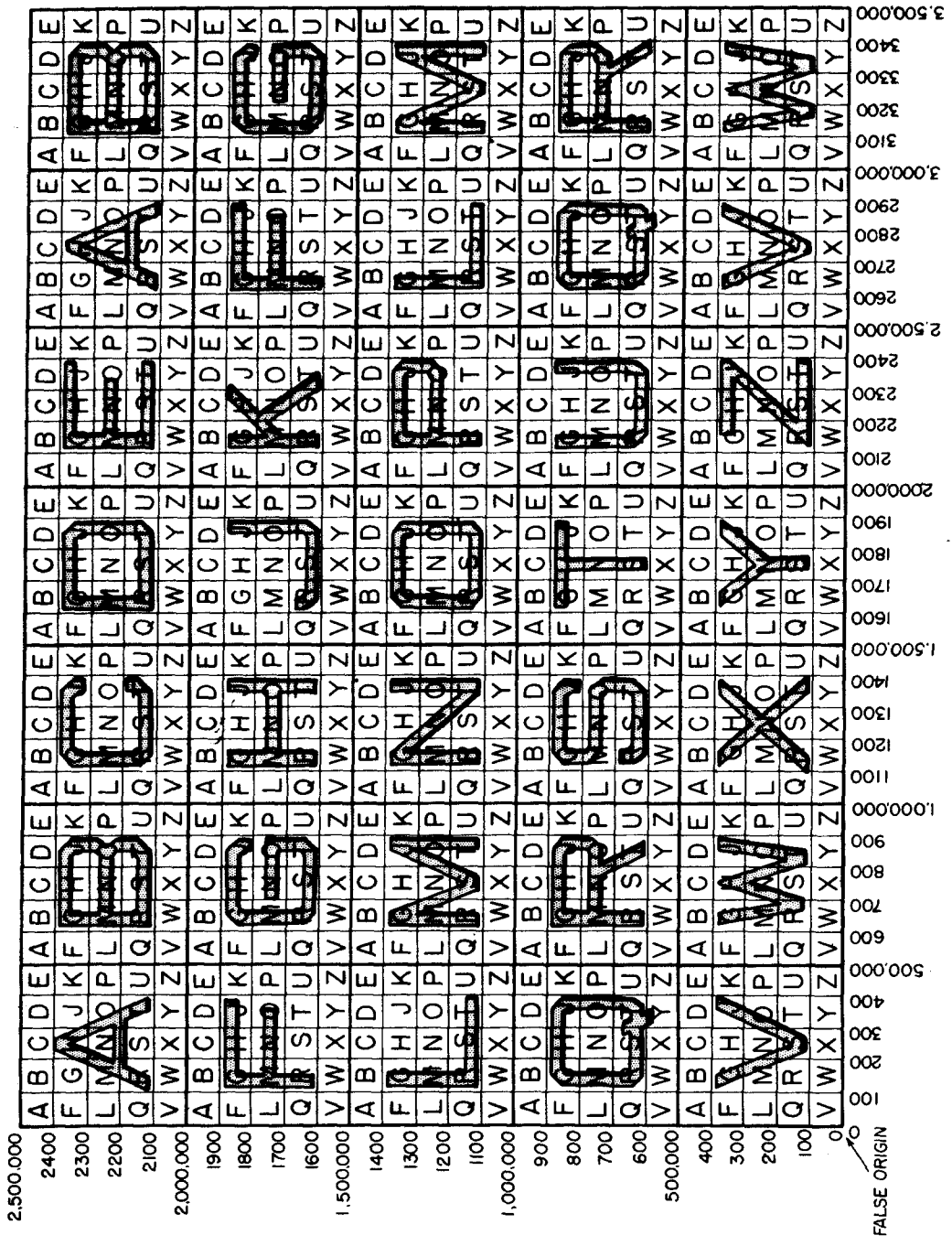

In the Normal lettering System the 500,000 unit Square letter V and the 100,000 unit Square letter V are both north and east of the false origin. This diagram can be used for bastard Systems of lettering by ignoring the values about the edge of the diagram and assigning appropriate values to the lines.

PLATE II. Diagram of the lettering system of the Modified British Grid.

numerical values, and the grid data for a particular zone are shown in the color characteristic of that zone. However, any one or all of the above three features are often printed in black for purposes of clarity or convenience.

Subdivision of zones and squares

The zone on which a grid is to be placed is subdivided by vertical and horizontal lines at 500-kilometer intervals, beginning at the southwest corner of the zone. The squares so formed are lettered alphabetically from left to right and from top to bottom in accordance with the lettering system in plate II. If the number of 500-kilometer squares with a given zone is greater than 25, the lettering system is repeated.

Each 500-kilometer square is subdivided by vertical and horizontal grid lines at 100-kilometer intervals. The grid squares so formed are lettered as shown in plate II.

The 100-kilometer squares are subdivided by vertical and horizontal grid lines at 1-kilometer intervals, every tenth grid line being accentuated. These lines are numbered consecutively from west to east and from south to north, beginning at or beyond the southwest corner of the grid zone. On maps of smaller scale than 1:100,000 only the accentuated 10-kilometer lines are shown, the scale of the map obviating the use of the 1-kilometer interval. Thus, on maps having scales of 1:100,000 and larger the grid interval is 1 kilometer; on maps of scale smaller than 1:100,000 the grid interval is 10 kilometers.

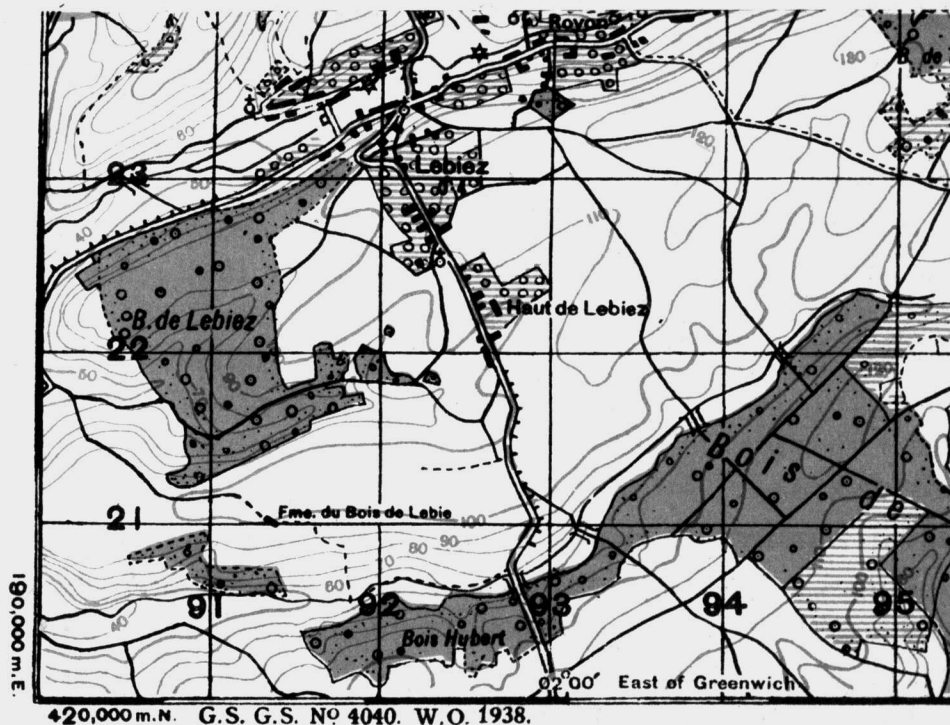

Figure 11. Section of map with Modified British Grid from France and Belgium Series, 1:50,000, G. S. G. S. 4040, Sheet 61.

Numerical value of grid lines

The numerical value of a grid line is dependent upon its distance from a false origin (see Glossary), located at or beyond the southwest corner of the grid zone. The values printed on the grid lines are abbreviated numbers indicating distances in thousands of meters. (See fig. 11.) The complete distances from which these grid values are derived are shown in the corners of the map. These full numbers are the distances from the false origin to the grid lines nearest the corners of the sheet.

It should be observed that only the abbreviated numbers printed on the grid lines are used in reading grid coordinates.

Parts of British grid coordinates

Complete British grid coordinates consist of four parts: (1) letter of the 500-kilometer square; (2) letter of the 100-kilometer square; (3) easting; (4) northing.

(1) The letter of the 500-kilometer square is written as a small capital and is inclosed in parentheses. It may be printed on the face of a map or in a marginal diagram.

(2) The letter of the 100-kilometer square is indicated by a large capital, which may be printed on the face of a map or in a marginal diagram.

(3) Easting is the British term for a west-east or X-coordinate.

(4) Northing is the British term for a south-north or Y-coordinate.

In writing British coordinates,¹ no parentheses, dashes, or decimal points are used with the easting and the northing. Such coordinates might appear as (s) B5784.

Point designation

To designate a point accurately, it is not always necessary to include the two letters which are used in complete British coordinates. If all references apply to a particular 500-kilometer square, the letter representing that square may be omitted. For example, the coordinates in the paragraph above might then appear as: B5784. When references apply to an area within the limits of a 100-kilometer square, the letter for that square may also be omitted. Thus, B5784 becomes 5784.

An equal number of digits must be included for both the easting and the northing. In the United States military grid systems the coordinates (34.5-28.4), (36.73-43.20), and (3.47-13.90), if written in British form, would appear as 345284, 36734320, and 03471390, respectively. Arbitrary systems of point designation, such as templates and thrust lines, are not used by the British Army.

¹ The rule of thumb used in United States map reading, "read right - up," applies when using the British grids.

Variations of the Modified British Grid System

Three variations of the Modified British Grid System as described above follow:

(1) The kilometer is not always the basis for the subdivision of grid zones. Some zones are subdivided with the 1,000-yard interval as the basis, instead of the 1-kilometer (1,000-meter) interval. Other than this change of basic unit of measurement, the system of subdivision, lettering, numbering, and designation of points remains exactly as described. The 1,000-yard interval is used on British-gridded maps covered by the following: India Zones, Ceylon Belt, Maldiv-Chagos Belt, Malay Grid, Johore Grid. (See plate I.)

(2) Some grid zones are not sufficiently large to warrant their subdivision into 500-kilometer lettered squares, and so they are first divided into 100-kilometer lettered squares. In such cases, the complete coordinates of points within these zones include the letter of the 100-kilometer square, the easting, and northing. The Johore Grid is in this category.

In the older British Grid System an area 50 kilometers square is covered by a grid composed of vertical and horizontal lines at 10-kilometer intervals. The 25 grid squares so formed are lettered alphabetically from left to right and from top to bottom, the letter "I" being omitted.

A	B	C	D	E
F	G	H	J	K
L	M	N	O	P
Q	R	S	T	U
V	W	X	Y	Z

Figure 12. Diagram of 50-kilometer square of the British Grid System.

Each of the 10-kilometer lettered squares is subdivided by grid lines at 1-kilometer intervals. These grid lines are numbered from left to right and from bottom to top.

Since the lettering system of the grids on adjoining 50-kilometer squares is the same, references are duplicated on maps covering an area one side of which measures more than 50 kilometers. The method of reading coordinates in the British Grid System is the same as that used in the Modified British Grid System.

SECTION III

JAPANESE TOPOGRAPHIC MAPS

INTRODUCTION

Japanese maps will be considered here only in a general way, because of the difficulty of obtaining information concerning them. Furthermore, Japanese characters are so complex that it is impossible to present enough of the written language to make one an accomplished reader of Japanese maps. Much of the material presented here has been obtained from a careful study of many Japanese maps. The purpose of this chapter is to give some of the characteristics of such maps and to explain the Japanese characters pertaining to numbers, dates, and representative fractions. Field sketches are used to a great extent by the Japanese Army in its operations, but are not discussed here.

Commercial maps used by the Japanese Army are published by the *Imperial Japanese Land Survey Bureau*. This bureau is a government monopoly. Other mapping agencies may not produce maps without its consent.

MILITARY MAP SERIES OF JAPAN

1:200,000 series

The 1:200,000 series of Japanese topographic maps covers a large part of the Japanese Empire. Topography is represented on these maps by green contours and green hill shading. Important settlements are shown in red, water features in blue, and all other objects in black.

1:50,000 series

The 1:50,000 series published by the *Imperial Japanese Land Survey Bureau* covers practically all of the Japanese Empire. This is a black-and-white contoured series containing a greater amount of detail than is usually found on United States maps of the same scale.

1:25,000 series

A few maps of 1:25,000 scale provide partial coverage of Japan. These sheets are dependable as of their date of publication.

United States maps of Japan

United States maps of Japan have been prepared on scales of 1:250,000, 1:50,000, and 1:25,000. The 1:250,000 series has been compiled from Japanese

1:200,000 and 1:50,000 sheets. The 1:50,000 United States series consists of maps copied in black and white from Japanese sheets of the same scale. A World Polyconic grid has been superimposed; transliterations have been provided in purple, and the Japanese legend has been translated into English. Colored editions at 1:50,000 scale are also being prepared. These have 1,000-yard World Polyconic grids and use modified symbols patterned after the original Japanese. Several sheets of a 1:25,000 United States Series, intended to cover the entire Japanese Empire, are available.

JAPANESE COORDINATE SYSTEMS

Geographic coordinates

Geographic coordinates are used on Japanese maps in the conventional manner. Longitude is measured east and west from the Greenwich meridian. Latitude is measured north and south from the equator. Meridians and parallels are not drawn on the face of the map, but the edges of the map are meridians and parallels. In this respect, Japanese maps are similar to German maps. Arabic numerals are used for the numerical values of meridians and parallels.

Military grid system

A standardized military grid system, similar to grids placed on United States, British, French, and German maps, has been established by the Japanese. According to the best available reports, this grid system uses a metric grid and consists of seven grid zones. Five zones cover Japan; one, Korea; and another, Formosa. Each zone is 4° in width. Those covering Japan are centered on the 132°, 136°, 140°, 144°, and 148° meridians; the zone covering Korea is centered on the 128° meridian, and that covering Formosa on the 121° meridian. The origin of each zone is the intersection of its central meridian with the 36° parallel, except the zone covering Formosa which has its origin at the intersection of the 121° meridian and the 24° parallel.

Grids on the Japanese zones, printed in brown, are metric, with a basic interval of 1 kilometer. Grid lines are numbered to the right and up, with only the 1,000- and 10,000-meter digits printed on the lines. Full values of grid lines are printed only on lines nearest the corners of the map and on those at even 100-kilometer intervals.

Japanese grid coordinates are read to the right and up.

Ordinarily only the abbreviated numerical values printed on the grid lines are used in giving grid references. A point whose full coordinates are 4553.7 E, 3979.8 N may be located by the abbreviated references 53.7/79.8 or 537.798.

Polar coordinates

Polar coordinates are used by the Japanese for point designation. Azimuths are

measured clockwise in degrees or in mils. Elements of polar coordinates are given in the following order: (1) reference or base point; (2) azimuth; (3) distance. An object 500 meters from a triangulation point 102 meters high on an azimuth of 1,800 mils would be indicated as follows: Base point

$$102 \quad \frac{1,800}{500m.}$$

CHARACTERISTICS OF JAPANESE TOPOGRAPHIC MAPS

Marginal information

Marginal information may be placed on Japanese maps as indicated in figure 13. Position of items of marginal information may vary on different maps and map series, and, certain items may not be found on some sheets.

The question: "How up to date and how accurate is the map?" can be answered by identifying the characters representing dates and the publishing agency. (See fig. 13 and Japanese characters p. 19.) Variations in place names are found on Japanese maps of different scales. Such variations are attributable to the Japanese custom of indicating names of small individual settlements on large-scale maps, but only those of village groups on maps of small scale.

Graphic scale

On Japanese maps a graphic scale graduated in metric units usually is found above the graphic scale in *ri*. The *shaku*, the *cho*, and the *ri* are the most important units of Japanese linear measurement. English and metric equivalents of these units follow:

<i>Japanese</i>	<i>English</i>	<i>Metric</i>
1 <i>shaku</i>	0.994 ft	30.3 cm
360 <i>shaku</i> = 1 <i>cho</i>	119.0 yd	109.0 m
36 <i>cho</i> = 1 <i>ri</i>	2.44 mi	3.93 km

Relief

Relief is represented on Japanese maps by contour lines, spot heights, and hill shading. These are employed singly or in combination.

Contours are printed in green on colored maps and indicate elevation in meters. Information on contour intervals may be found in a relief diagram under the legend at the lower left corner. Elevations of contour lines, expressed in Arabic numerals, are given on some maps at points where the contour lines meet the edges of the sheet.

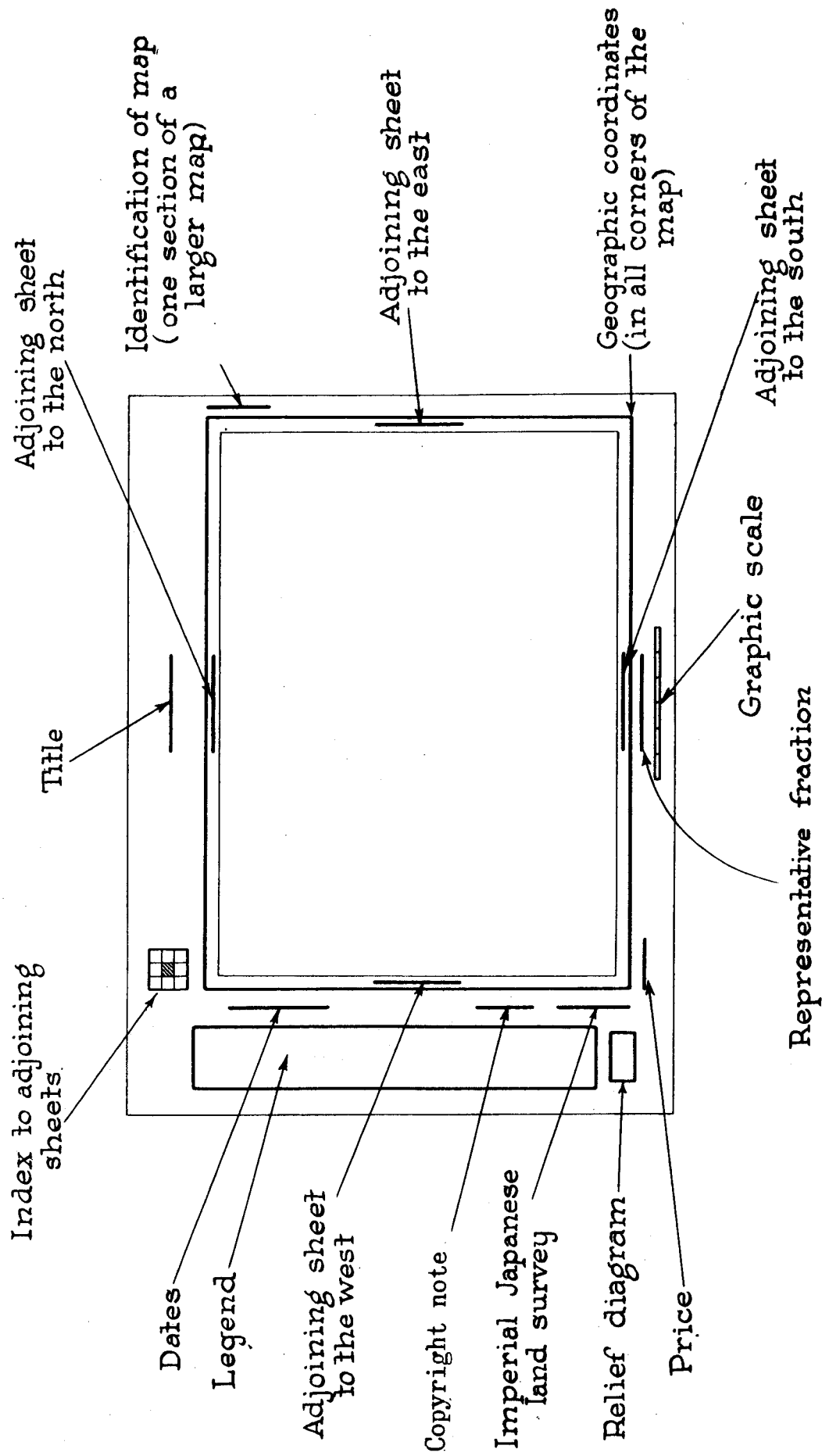

Figure 13. Diagram showing approximate positions of various items of marginal information on Japanese maps.

Every fifth contour line may be accentuated. Broken contours represent smaller intervals than do the contours shown by solid lines. The former supplement regular contour lines when regular contours alone will not give a sufficiently detailed picture of land forms. Craters or depressions in the terrain are indicated on a topographic map by small arrows. The Japanese contouring system is similar in several respects to the German.

Elevations indicated by spot heights, bench marks, and triangulation points are printed in Arabic numerals, for example, 23.4. A figure with a horizontal line above it, for example, $\overline{23.4}$, may be found on rivers and streams to indicate the depth of the water.

Hill shading in green supplements contours on colored maps.

JAPANESE CHARACTERS

System of writing numbers

A knowledge of the Japanese system of writing numbers is necessary to the map reader when deciphering representative fractions and dates from Japanese maps. The basic characters illustrated below are used on maps published by the *Imperial Japanese Land Survey Bureau*. More intricate symbols for numbers are used on other maps, for example, the symbol representing 10,000. The basic characters for numbers are as follows:

1	一	6	六	10	十
2	二	7	七	100	百
3	三	8	八	1,000	千
4	四	9	九	10,000	万

Combinations of numbers may be written in any one of three ways: top to bottom, left to right, or right to left. In the examples which follow, read the left column of symbols from top to bottom, the middle column from left to right, and the right column from right to left.

Note that in the first two examples, the second character is added to the first.

11 十 or 十一 or 一十

15 十五 or 十五 or 五十

In the following examples, the second character is multiplied by the first, and the third character is added, for example, "three tens, seven," or 37.

37 三十
 七 or 三十七 or 七十三

94 九十
 四 or 九十四 or 四十九

The next group of characters may be interpreted: "one one hundred, nine tens, three," or 193.

193 一百
 九 or 一百九十三 or 三十九百一
 十三

The principles developed above are further illustrated in the following examples:

3,794 三千七百九十四 or 三七九四 or 四九七三

50,000 五万 or 五万 or 万五

Some numbers, such as 二十 and 三十六, may be read as 20 or 12 and 36 or 63, respectively. When such cases arise, the reader should compare other figures on the sheet to determine the direction in which figures must be read.

Although it is not found on their maps, the Japanese also use another numbering system with figures written as in the Arabic system. The number 3794, for example, is written:

三七九四 or 三七九四 or 四九七三

As in the first system described, these numbers may be read in both directions.

Dates

Japanese dates are calculated from the beginning of one of three reigns: Meiji (1868-1912); Taisho (1912-26); Showa (1926--). To convert the Japanese year into our calendar, add to the number of the Japanese year one of the following dates: Meiji 1867, Taisho 1911, Showa 1925, depending on the Japanese period indicated. Therefore, Meiji 40 would become 1907 (40 plus 1867); Taisho 9, 1920 (9 plus 1911); and Showa 16, 1941 (16 plus 1925).

Japanese dates are preceded by a reign, each of which is represented by the below:

Meiji 明治

Taisho 大正

Showa 昭和

Characters for year, month and day are as follows:

Year 年

Month 月

Day 日

The entire date appears as:

明治三十年五月二十三日

Representative fractions

The characters indicating representative fractions appear on Japanese maps above the graphic scales. The four Japanese characters 尺之一分 symbolize to a Japanese what the words “representative fraction equals 1: _____” would symbolize in English, although they are not literally translatable in this fashion; the characters which precede or follow them indicate the denominator of the representative fraction or the second half of the ratio.

Example: 尺之一分万十二 and 尺之一分万五 are the characters for 1:200,000 and 1:50,000, respectively. Representative fractions may be written in reverse order to that shown above, for example, 二万五千分之一之尺 is 1:25,000. If the four characters, 尺之一分, are written on the left, read the rest of the representative fraction from the right. If these four characters are on the right, read the remaining characters from the left.

GLOSSARY OF JAPANESE MAP EXPRESSIONS

Authorities

大日本帝國陸地測量部

Imperial
Japanese
Land
Survey
Bureau

陸地測量部

Land
Survey
Department

Key terms for identifying map dates

測量 or 測圖 survey

製版 engraving made

發行 published

印刷 printed

再版 or 改版 reprint

修正 revised

部分 part, section

要部 important section

第二回 second time

同 ibid., the same reference (refers to reign, reign and year last stated, or entire date last stated).

Units of linear measurement

耗 millimeter

厘 centimeter

米 meter

料 kilometer

尺 shaku

町 cho

里 ri

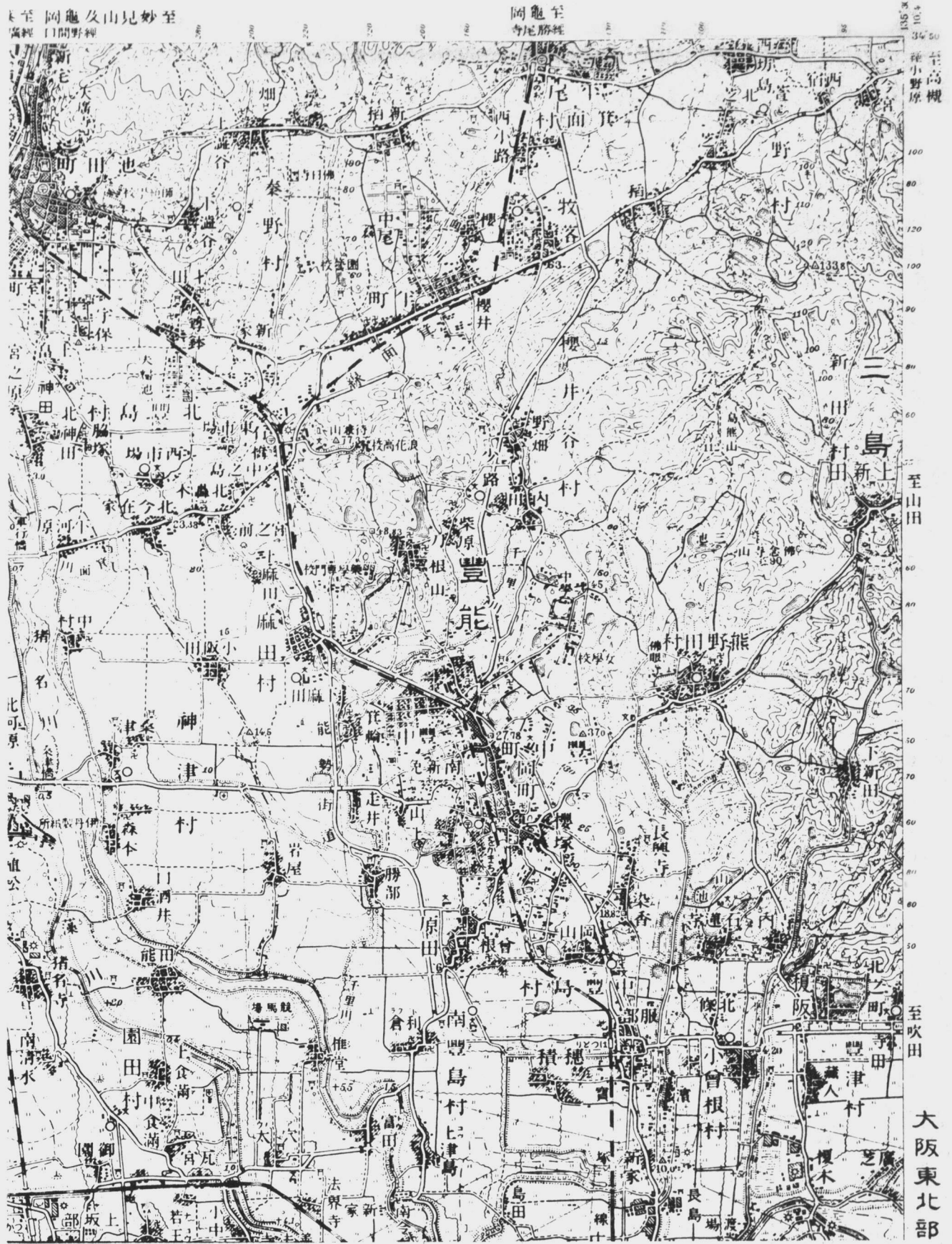

Plate III. Section of map from original Japanese Series, 1:50,000, Sheet 12.

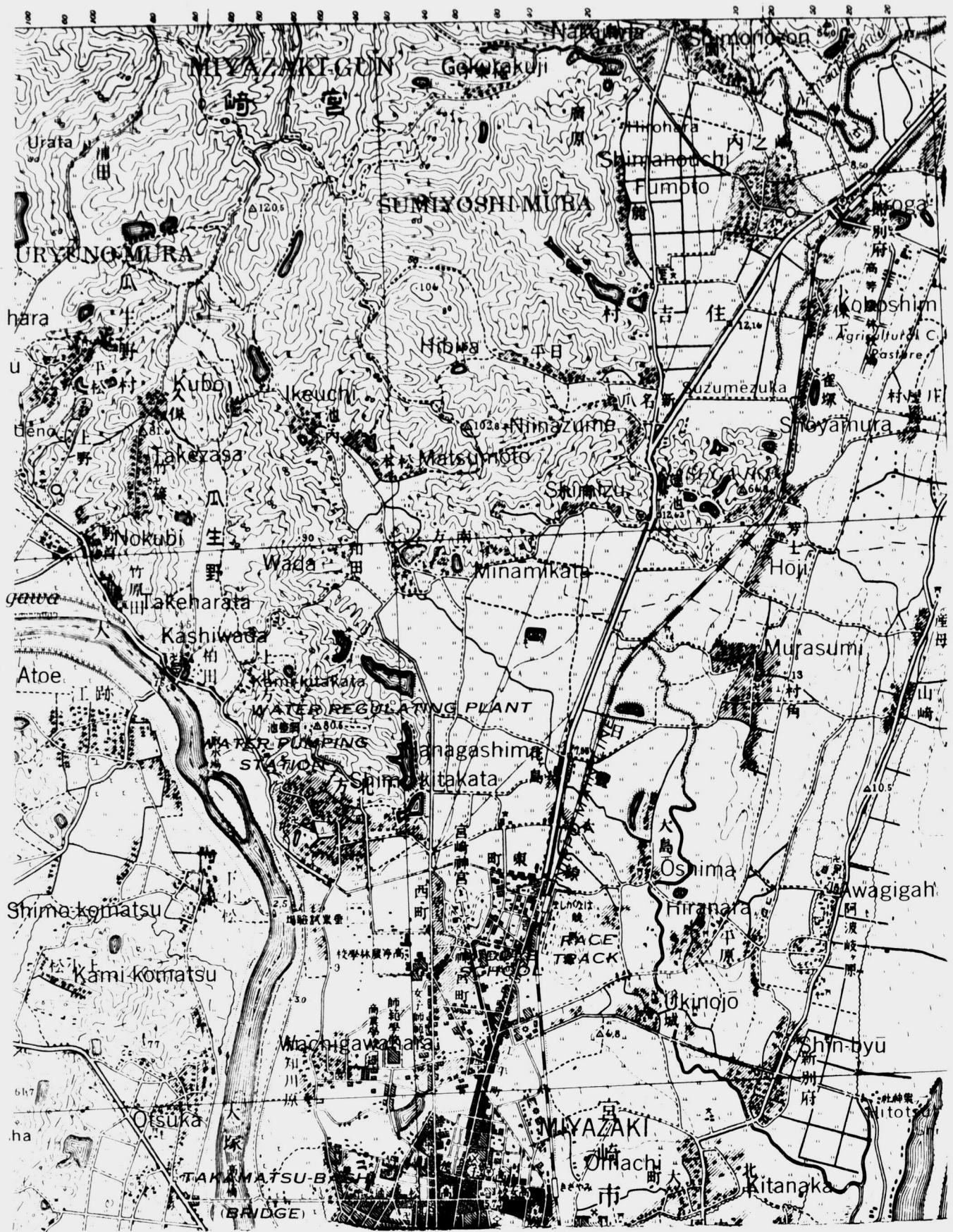

Plate IV. Section of map from Kyūshū Series, 1:50,000, AMS L772, Sheet 133.

SECTION IV

CHINESE MILITARY MAPS

INTRODUCTION

Chinese military maps are published by the *Chinese Central Land Survey*. This agency is part of the Survey Department of the Chinese General Staff. The *Central Land Survey* not only conducts field surveys, but also establishes cartographic standards and directs the activities of its units in the various provinces. In spite of the efforts of the *Central Land Survey* to coordinate the activities of these provincial units, many discrepancies are found among the map series of the various provinces.

MILITARY MAPS OF CHINA

Chinese General Staff map series

Chinese General Staff map series are published on scales of 1:100,000, 1:50,000, 1:25,000, and 1:10,000. These may be encountered in two "styles". Maps published prior to 1935 are classified "Old Style" maps. The form of these "Old Style" sheets is not consistent. The sheets were made from sources of varying accuracy, and in many instances boundaries on maps of adjoining provinces do not agree. The "New Style" sheets, published since 1935, follow a more definite form than the older maps; they have a military grid and are fairly reliable. These improvements in the "New Style" sheets can be attributed to the close supervision exercised by the *Central Land Survey* in the preparation of these maps.

CHINESE COORDINATE SYSTEMS

Geographic coordinates

Geographic coordinates are used by the Chinese on their topographic maps. The degree system is used exclusively. Latitude and longitude are based on the equator and the Greenwich meridian, respectively. On a few old Chinese maps, longitude is measured from the meridian of Peking.

Chinese military grid

The Chinese military grid is used on Chinese maps published since 1935. A series of latitudinal overlapping zones was established. These zones appear to cover 3° 30' of latitude and extend east and west across China. The origin of each zone is the intersection of the 105° meridian and the parallel forming its southern limit.

The grid on each zone is a metric grid with a basic interval of one kilometer. Grid lines are numbered from west to east and from south to north. As on maps of other countries, the full numerical value of grid lines is indicated on those lines nearest the corners of the map, and abbreviated values are found on the remaining lines.

CHARACTERISTICS OF CHINESE MILITARY MAPS

Marginal information

The marginal information found on Chinese maps is scanty when compared with that found on maps of other countries. Figure 15 shows the type and approximate position of marginal information on Chinese maps. The exact nature and position of the various items may vary with the series.

When evaluating a Chinese map due consideration should be given to the general characteristics of Chinese mapping. The differences in mapping technique of the many provincial mapping units result in a lack of uniformity and consistency.

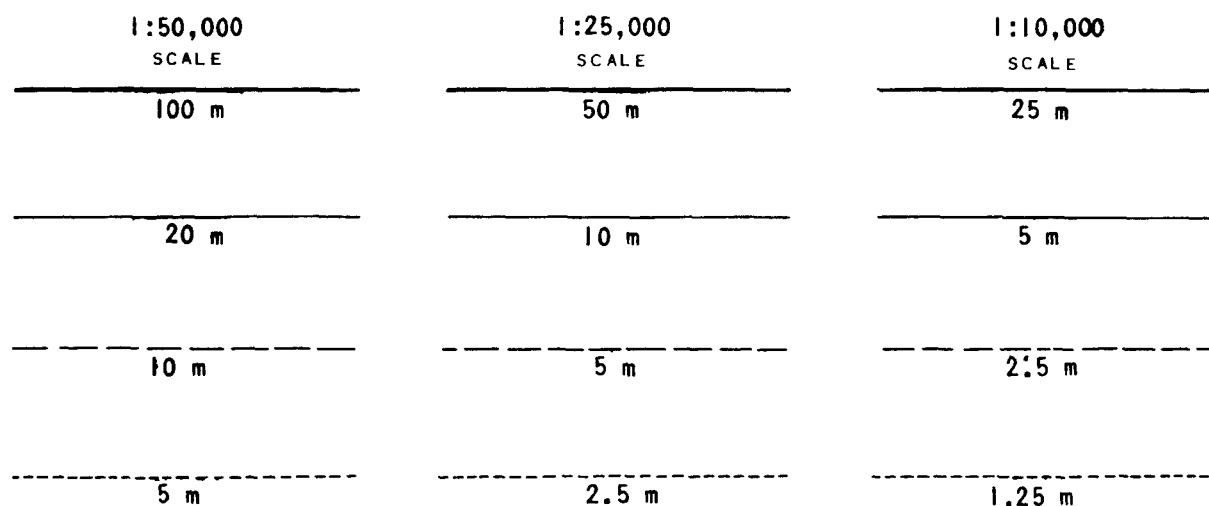

Figure 14. Contours used on Chinese maps.

Graphic scales

Graphic scales in kilometers and in *shi li* will be found in the lower margin of a Chinese map. The kilometer scale is usually the upper one. The *shi li*, as used on Chinese General Staff maps, is equivalent to 500 meters. However, on maps other than General Staff maps, this particular unit of measure may vary in length in the different Chinese provinces. Although the metric system has been officially adopted in China, the older Chinese units still may be encountered. (See Appendix, p. 47.)

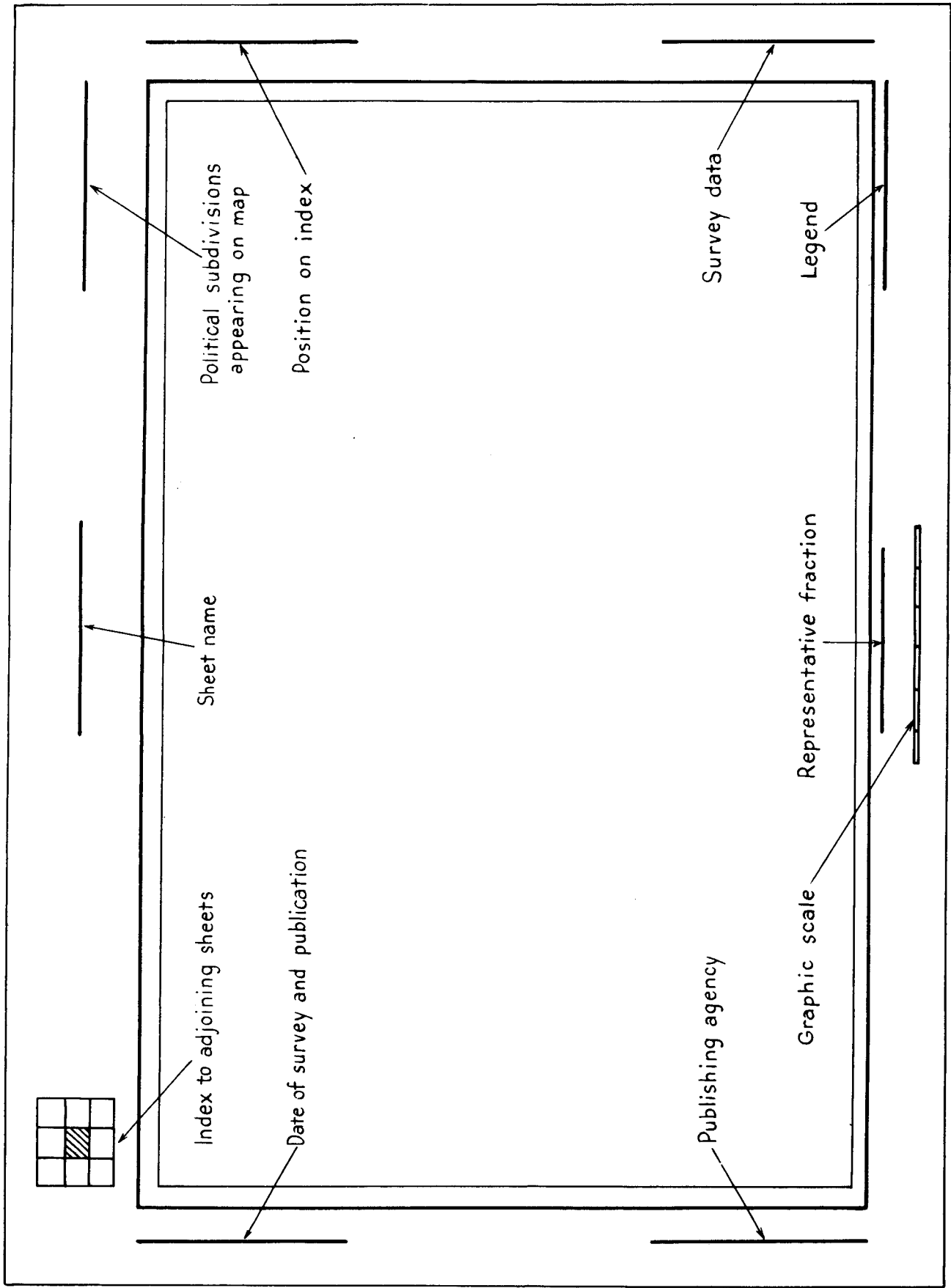

Figure 15. Diagram showing position of marginal information on Chinese maps.

Relief

Relief is shown on Chinese maps by means of contours, supplemented by shading and spot heights.

Four types of contour lines are found on maps of China. The symbols used are the same for maps of all scales. However, the symbol representing a particular interval on a map of one scale will represent a different interval on a map of another scale.

An unusual type of *shading*, combining some of the characteristics of both hachuring and hill shading, is also used on Chinese maps to represent topography. This means of showing relief is found on contoured maps in many areas having very steep slopes or rough terrain. (See fig. 16.)

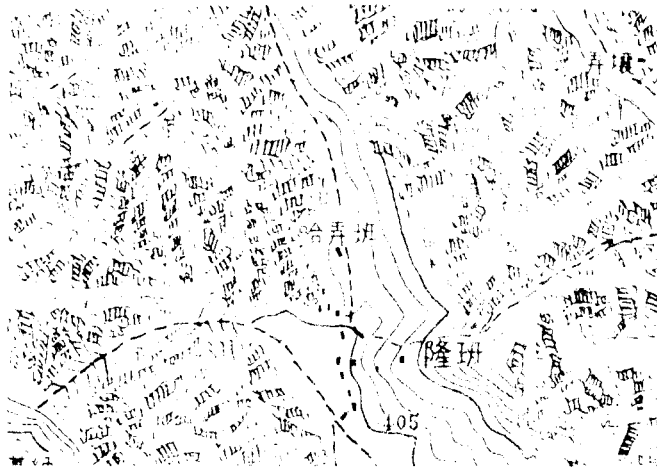

Figure 16. Section of Chinese map, 1:50,000. Note method of representing rough terrain.

Spot heights supplement other methods of indicating relief. Elevations are given in meters.

Caution should be exercised in interpreting relief on Chinese maps. Vertical data is not consistent in all provinces, nor are all elevations necessarily measured from sea level. The elevations appearing on maps of any one province do little more than show relative differences in altitude.

CHINESE CHARACTERS

System of writing numbers

A knowledge of the Chinese method of writing numbers, representative fractions, and dates is necessary when reading a Chinese map. In addition, familiarity with certain characters commonly found in the marginal information will be helpful to the map reader.

The Chinese characters for numbers and representative fractions are the same as those of the Japanese described in the previous chapter. About the eighth century, the Chinese system of characters was adopted by the Japanese. This explains the similiarity between the written language of the two countries.

Dates

Dates on maps published by the *Chinese Central Land Survey* are calculated from the first year of the Chinese Republic (Chung Hua Ming Kuo), 1912. To convert a Chinese year to our calendar, add 1911 to the number of the Chinese year. Thus, Chung Hua Ming Kuo 1 is 1912, and Chung Hua Ming Kuo 30 is 1941.

Two other eras may be used as starting points in converting Chinese dates prior to 1912 to our calendar. These are the Kuan Tsui Tzi, 1875, and Hsuan Tung Tzi, 1908. Dates earlier than 1875 are calculated from other eras not listed here.

The characters for the above-mentioned eras are:

Kuan Tsui Tzi

光緒紀

Hsuan Tung Tzi

宣統紀

Chung Hua Ming Kuo

中華民國

The characters representing year, month, and day are:

year

年

month

月

day

日

Thus, the 25th year of the Chinese Republic, 1936, will be represented by the characters:

中華民國二十五年

GLOSSARY OF CHINESE MAP EXPRESSIONS*

Authorities

參謀本部
陸地測量總局

Head Office, Land Survey,
General Staff

測量分局

Branch Survey Office

Key terms for identifying map dates

版權

----- copyright

再版

or

重印

----- reprinted

軍用本

----- official edition

測量

----- surveyed

寫真石印

----- photolithographed

印刷

----- printed

修正

----- revised

Directions

北

----- north

西

----- west

東

----- east

南

----- south

* "Glossary of Selected Map Terms . . .," March 1914, Army Map Service, Corps of Engineers, U. S. Army, Washington, D. C.

Units of linear measure

公里	kilometer
公尺	meter
公分	centimeter
市里	<i>shi li</i>
丈	<i>chang</i>

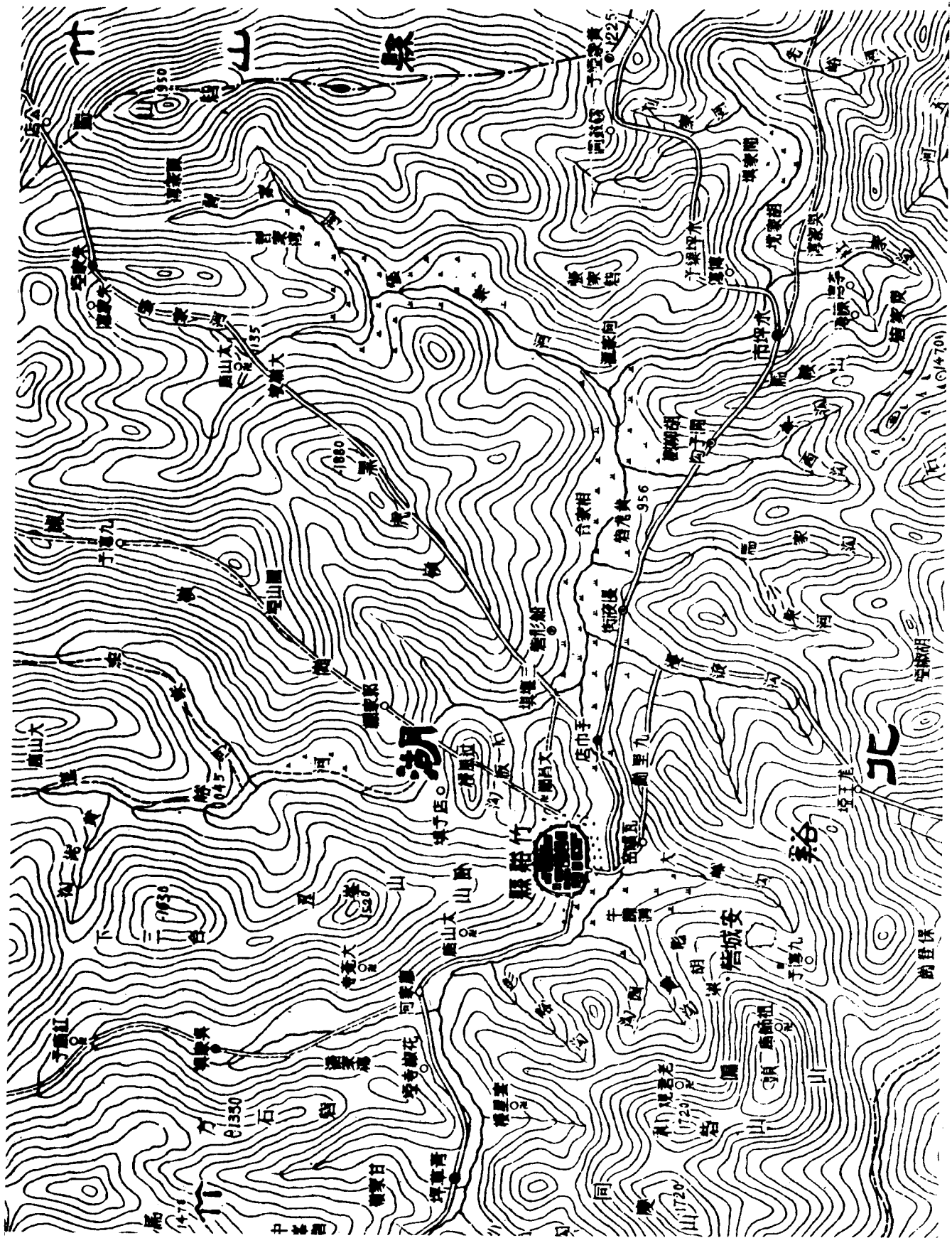

Plate V. Section of map from China Series, 1:100,000.

SECTION V

MISCELLANEOUS MILITARY MAPS OF THE FAR EAST

BURMA, INDIA, AND MALAYA

Military maps of Burma and India are published by the *Survey of India*. This agency, directed by the Surveyor General of India, also publishes maps of Tibet, Indo-China, Thailand, Iran, Iraq, and Arabia.

Burma and India are adequately covered by maps scaled at 1:253,440, 1:126,720, and 1:63,360. Burma is covered by an additional series of 1:25,000 scale. Geographic coordinates are expressed in degrees, and longitude is measured from Greenwich. British grids in yards are found on most of the maps. Relief is shown by contours, hachures, and spot elevations. In many areas, particularly those mapped at a very early date, the contours are only approximate. Hachures are used on many maps. All elevations are given in feet.

Topographic maps of Malaya are published under the direction of the Surveyor General of the Federated Malay States and Straits Settlements. These maps are drawn to scales of 1:63,360 and 1:25,000. They have British yard grids, and longitude is measured in degrees from Greenwich.

FRENCH INDO-CHINA

The *Service Geographique de l'Indo-Chine* publishes military maps of French Indo-China. The east coastal region and the southern part of the country are covered by a 1:100,000 series of maps. Strategic areas are further mapped on a scale of 1:25,000. Geographic coordinates are expressed in the grade (centesimal) system with longitude based on the meridian of Paris. A Lambert grid is used on some maps.

British maps of French Indo-China are based on the original 1:100,000 series published by the *Service Geographique de l'Indo-Chine*. Geographic coordinates in degrees and minutes supplement the grade system, and a British grid has been superimposed.

NETHERLANDS EAST INDIES

The original surveying and mapping of the Netherlands East Indies was done by the *Topografische Dienst*. All of Sumata, Bali, and Java, except for the interior, have been surveyed trigonometrically; the remainder of the Netherlands East Indies has been mapped from reconnaissance surveys. Hydrographic surveys and systematic charting of the waters and coast lines have been conducted by the *Afdeeling Hydrografische van het Ministerie van Defensie*

(Netherlands) and the British Admiralty. Extensive use of aerial photography in mapping was begun in 1931, and since that time, areas of Borneo, Netherlands New Guinea, and the remainder of Sumatra have been mapped from air photos.

Six types of maps have been produced by the Dutch in the Netherlands East Indies.

Militaire Kart

The *Militaire Kart* ("Military Maps") have a minimum scale of 1:50,000 and, since they have been fully surveyed, are accurate for artillery fire control.

Topografische Kart

Topografische Kart ("Topographic Maps") are partially surveyed and accurate for all military purposes except artillery fire. Minimum scale is 1:200,000.

Topografische Schetskaart

Topografische Schetskaart ("Reconnaissance Topographic Maps") are incompletely surveyed and have a minimum scale of 1:200,000.

Verkenningskaart

Verkenningskaart ("Reconnaissance Maps") have been compiled from uncontrolled data with little or no survey material. The scale is generally larger than 1:200,000.

Overzichtskaart

Overzichtskaart ("General Maps") and *Schetskaart* ("Reconnaissance Maps") are compiled from topographic maps, the latter from less reliable data than the former.

TYPES AND REVISIONS

Types

Maps of the Netherlands East Indies may be divided into two types: pre-1916 and post-1916. Many of the pre-1916 type were black and white editions, although some were printed in colors. The newer sheets, published since 1916, besides being more detailed and more accurate, are printed in colors. Symbolization and classification of works of man are more detailed on the newer editions.

Revisions

Three types of revision may be found on maps of the Netherlands East Indies. (1) Simple revisions of reprinted maps, such as changes in road classifications or

place names, are identified by the Dutch word *Herdruk*. (2) A more extensive revision is identified by the term *Gewijzigde Herdruk*. (3) A complete revision or entirely new edition, *Hermeten*, constitutes the third type.

The date of revision is used by the *Topografische Dienst* for indicating the date of a map wherever possible. In the event that a Dutch map contains no date of revision in its marginal information, the date of reproduction may be found in the lower left corner. The date of survey may be found in the center of the upper margin if the first two dates are lacking.

Scales

The most commonly used scales for maps of the Netherlands East Indies are 1:200,000, 1:100,000, 1:80,000, 1:40,000, and 1:20,000. Other scales may be used.

Geographic coordinates

Geographic coordinates are expressed in the degree or sexagesimal system. The following prime meridians are used by the *Topografische Dienst*:

Batavia	106°48'28" E. of Greenwich.
Padang	100°22'02" E. of Greenwich.
South Sumatra	103°33'28" E. of Greenwich.
Singkawang	108°59'41" E. of Greenwich.
Middle Celebes	121°48'28" E. of Greenwich.

Military grid system

The Dutch use their own military grid on maps of the Netherlands East Indies. This grid is a metric grid based on both Mercator and polyhedral projections, but exact boundaries and details of the various zones are not known. The grid interval on large-scale maps is one kilometer. Coordinates are read to the right and up.

Relief

Relief on Dutch maps of this area is shown by contours and spot heights; elevations are measured in meters. The contour interval is 1/2000 of the denominator of the scale. Hence, the contour interval on a 1:100,000 map is 50 meters, while that of a map drawn to the scale of 1:50,000 is 25 meters. Hill shading is sometimes used to supplement contours and spot heights.

Symbols

Symbolization on the maps of the Netherlands East Indies is clear, complete, and detailed. Roads, railroads, types of buildings, cultivated areas, and other works of man are classified in detail. Color is used to indicate native settlements and inhabited areas. Care should be used to prevent confusing this symbol with

that of a wooded area. A list of abbreviations used on the map may be found in the legend. A series of notes, *Toelichtingen*, providing information pertinent to survey data, boundaries, and communications not found elsewhere on the map are also included as a part of the legend.

United States maps

United States maps of the Netherlands East Indies have been reproduced from the Dutch originals. Colored, as well as black and white halftone, reprints have been made, and some sheets compiled. Original Dutch symbolization is retained, although a few minor modifications in style are made for the sake of uniformity. British grids are used throughout the greatest portion of the Netherlands East Indies. The U. S. Yard Grid, N.E.I. Equatorial Zone, has been established to replace the British grids in the northern part of this area. This grid uses 500,000-, 100,000-, and 1,000-yard squares in the same manner as the British yard grids and coordinates are written in the British manner.



Plate VII. Section of map from Burma and Thailand Series, 1:253,440
 Provisional G. S. G. S. 4218, Sheet F-47D.

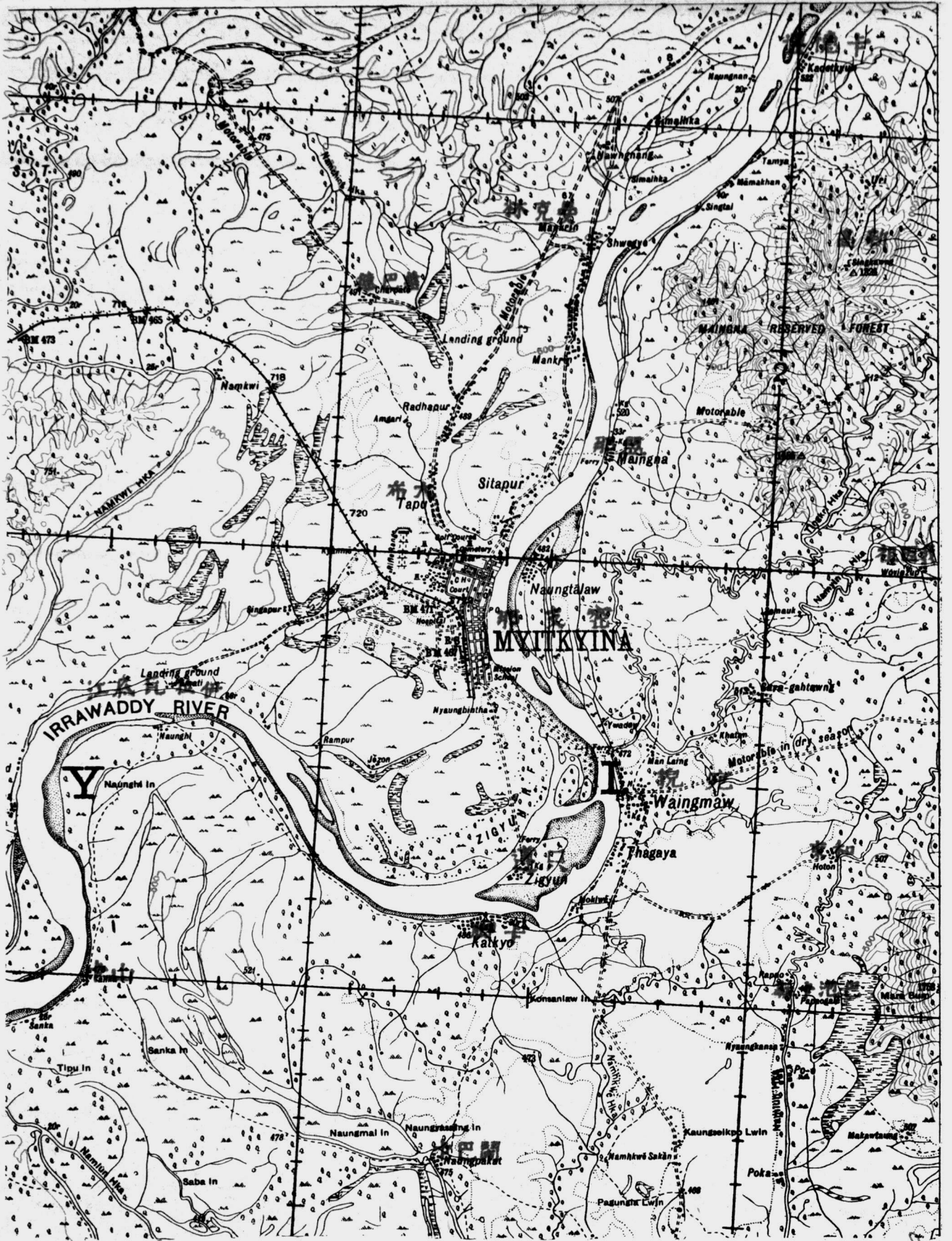

Plate VIII. Section of map from Burma Series, 1:126,720, Sheet 92G/SW.

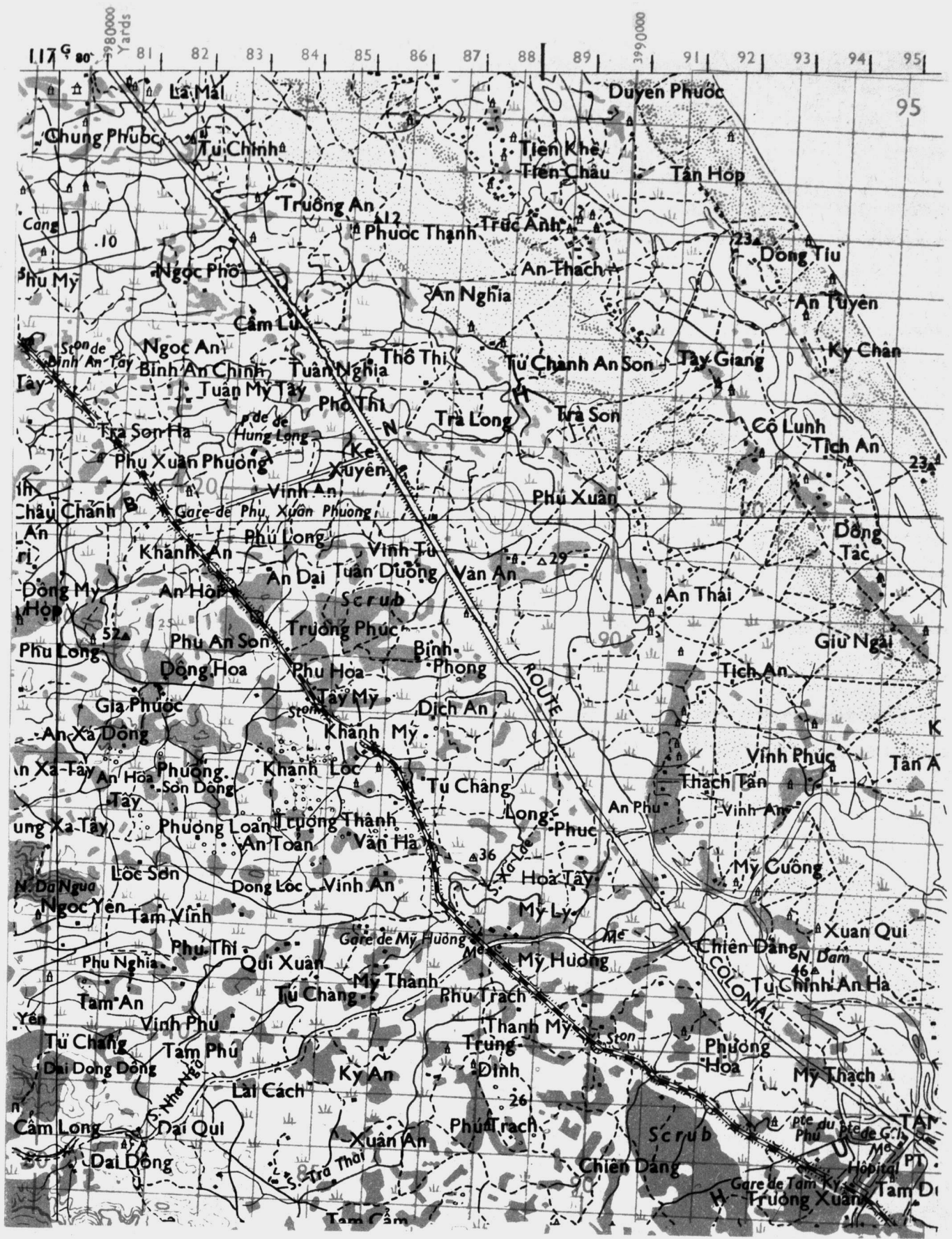

Plate IX. Section of map from Indo-China Series, 1:100,000, HIND, Sheet No. 137 (East).

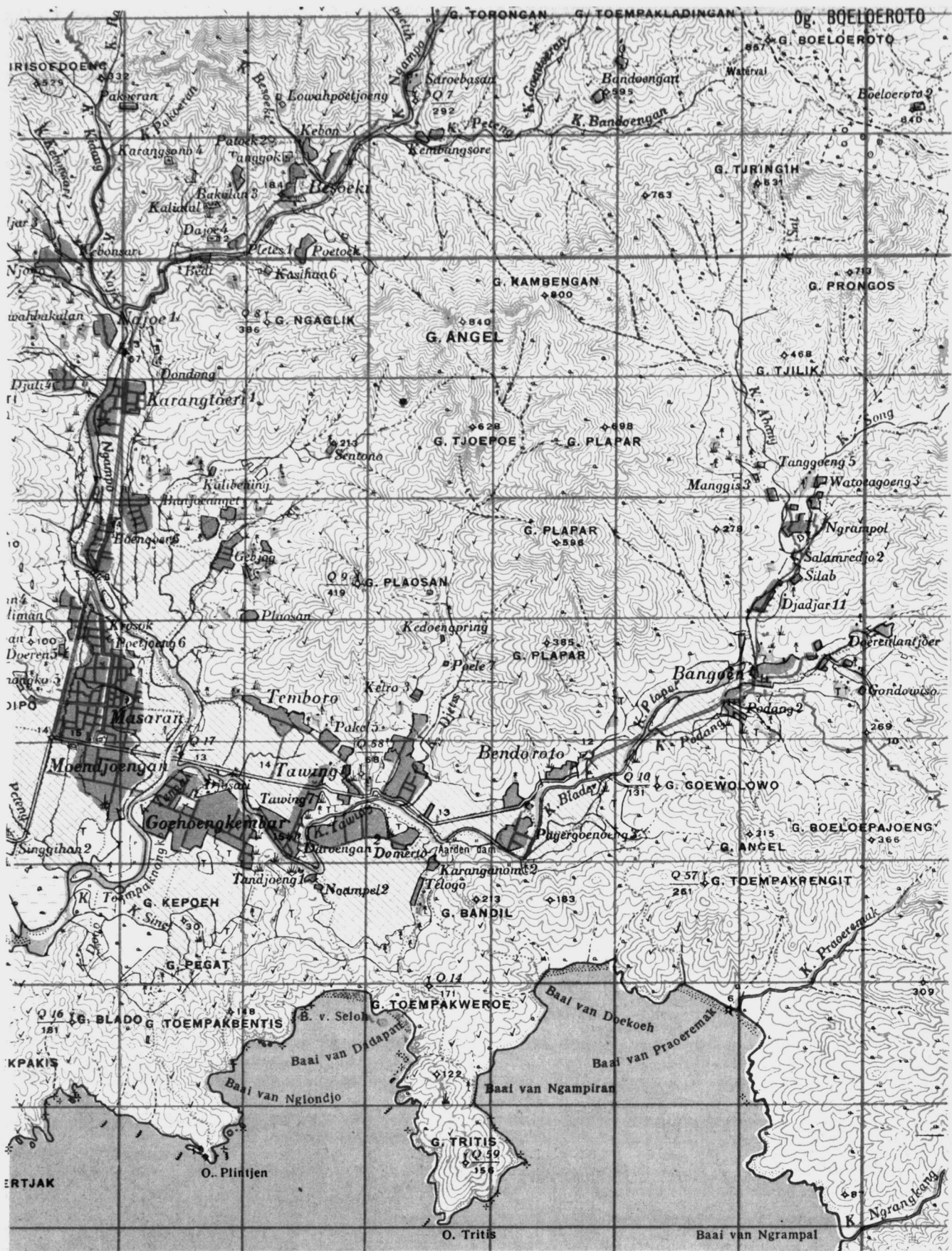

Plate X. Section of map from Java and Madura Series, 1:50,000, G. S. G. S. 4202, Sheet 51/XLIII-C and 51/XLIV-A.

APPENDIX

Chinese System of Linear Measure (with Equivalents in Metric and English Systems)

	1 <i>hou</i>	0.032 millimeter	0.0012 inch
10 <i>hou</i>	1 <i>li</i>	0.32 millimeter	0.0125 inch
10 <i>li</i>	1 <i>feng</i>	3.2 millimeters	0.1259 inch
10 <i>feng</i>	1 <i>chun</i>	3.2 centimeters	1.259 inches
10 <i>chun</i>	1 <i>chi</i>	32.0 centimeters	12.59 inches
10 <i>chi</i>	1 <i>chang</i>	3.2 meters	10.49 feet
180 <i>chang</i>	1 <i>shi li</i>	576.0 meters	1889.28 feet

(Note. When the length of the *shi li* differs from that shown above, all other units are correspondingly changed in length.)

Chinese System of Linear Measure (as Used on Chinese General Staff Maps)

	1 <i>chang</i>	3.333 meters	10.935 feet
150 <i>chang</i>	1 <i>shi li</i>	500.0 meters	1640.5 feet

Equivalent Units of Angular Measure

1 mil	1/6400 circle	0.0166 degree	0.0185 grade
1 grade	1/400 circle	16.0 mils	9/10 degree
1 degree	1/360 circle	17.8 mils	10/9 grades

Conversion Factors

To convert —	Multiply by —	
	<i>Exact</i>	<i>Approximate</i>
Inches into centimeters.....	2.540	2.5
Feet into meters.....	0.3048	0.3
Yards into meters.....	0.9144	0.9
Miles into kilometers.....	1.609	1.6
Centimeters into inches.....	0.3937	0.4
Meters into feet.....	3.281	3.3
Meters into yards.....	1.094	1.1
Kilometers into miles.....	0.6214	0.62
Grades into degrees.....	9/10	-----
Grades into mils.....	16.00	-----
Degrees into grades.....	10/9	-----
Degrees into mils.....	17.77	17.8

**Prime Meridians used on Foreign Maps
with Longitudinal Distances from Greenwich**

Amsterdam 4° 53' 05" E.	Moscow 37° 34' 15" E.
Athens 23° 42' 59" E.	Oslo 10° 43' 23" E.
Batavia 106° 48' 28" E.	Padang 100° 22' 01" E.
Brussels 4° 22' 13" E.	Paris 2° 20' 14" E.
Copenhagen 12° 34' 40" E.	Peking 116° 28' 10" E.
Ferro	Pulkovo 30° 19' 38" E.
(French value) 17° 39' 46" W.	Rome 12° 27' 07" E.
(German value) 17° 40' W.	Singkawang 108° 59' 41" E.
Istanbul 28° 59' 20" E.	Stockholm 18° 18' 30" E.
Lisbon 99° 11' 10" W.	Tokyo 139° 44' 41" E.
Madrid 3° 41' 15" W.	

LEGENDS

The legends illustrated on succeeding pages are taken from United States and British maps of foreign countries. The maps from which the legends are taken are copied maps which have retained the original foreign symbols. Therefore, these legends are equally applicable to the United States and British editions and to the foreign originals from which the United States and British copies were reproduced.

LEGEND

Density of Construction in Urban Areas

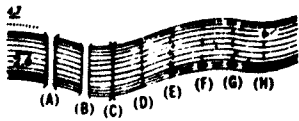

- (A) Iron Bridge
- (B) Wooden Bridge
- (C) Foot Bridge
- (D) Foot Ford
- (E) Vehicular Ford
- (F) Passenger Ferry (Single Boat)
- (G) Passenger and Horse Ferry (Two Boats)
- (H) Steam Ferry

42 Height of Bank
53 Depth of Water

- ⊙ Lighthouse
- ⊥ Boat Anchorage
- ⊥ Ship Anchorage
- ⊥ Anchorage
- ⊙ Radio Mast
- ⊙ Warning Signal
- ⊙ Commercial Port
- ⊙ Fixed Beacon
- ⊙ Fixed Beacon (Lightless)
- ⊙ Buoy (Lightless)



- (A) Flower Garden
- (B) Grove
- (C) Truck Garden

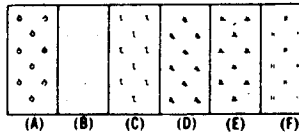

- (A) Orchard
- (B) Tea
- (C) Mulberry
- (D) Cultivated marsh
- (E) Irrigated Rice Field
- (F) Dry Rice Field

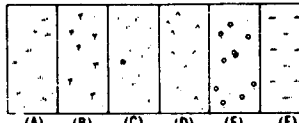

- (A) Wild Land
- (B) Palm
- (C) Bamboo
- (D) Conifers
- (E) Broad-leaf Trees
- (F) Grass Land



- (A) Cliff
- (B) Rock Outcropping
- (C) Scattered Rock
- (D) Talus Slope
- (E) Depression
- (F) Ravine, Gully

- ⊙ Navy Lookout Tower
- ⊙ Factory
- ⊙ Bank
- ⊙ Powder Magazine
- ⊙ Water Wheel or Mill
- ⊙ Generating Plant
- ⊙ Shrine
- ⊙ Temple
- ⊙ Grave
- ⊙ Pagoda
- ⊙ Church
- ⊙ Japanese Government Building
- ⊙ Foreign Government Building
- ⊙ Military Reservation
- ⊙ Naval Reservation
- ⊙ Division Headquarters
- ⊙ Brigade Headquarters
- ⊙ Fortress and Defense Headquarters
- ⊙ Battalion Headquarters and Garrison
- ⊙ Regimental Headquarters
- ⊙ Naval Station
- ⊙ Secondary Naval Station
- ⊙ Naval Camp
- ⊙ Army Camp
- ⊙ Shipyard
- ⊙ Prefectural Seat
- ⊙ Sub-prefectural, Island-office or Gun Seat
- ⊙ City Office
- ⊙ Town, Village or Ward Office
- ⊙ School
- ⊙ Hospital
- ⊙ Isolation Hospital
- ⊙ Gendarmerie Post
- ⊙ Police Station
- ⊙ Court of Appeals
- ⊙ Prison
- ⊙ Customs House
- ⊙ Tax Office
- ⊙ Forestry Office
- ⊙ Mining Office
- ⊙ Government Monopoly Bureau Office or Factory
- ⊙ Office of Maritime Affairs
- ⊙ Meteorological Station
- ⊙ Post Office (with Telegraph and Telephone service)
- ⊙ Post Office
- ⊙ Telegraph Office
- ⊙ Telephone Office
- ⊙ Boundary Marker

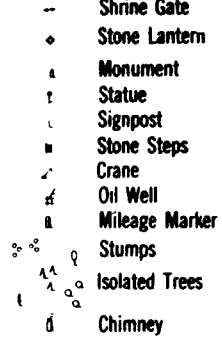
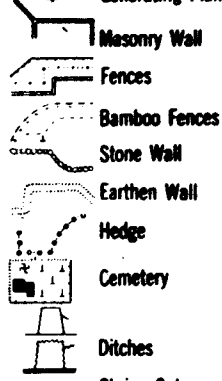

- 96.1 Triangulation Point
- 365.37 Secondary Control Point
- 423.42 Bench Mark
- 32.5 Spot Elevation
- ⊙ Old Battlefield
- ⊙ Spring
- ⊙ Tomb
- ⊙ Castle Site
- ⊙ Volcano
- ⊙ Mineral Spring
- ⊙ Material Dump
- ⊙ Mine

All above Sea Level

GLOSSARY

VARIANTS IN PARENTHESES

- bae (-hae) rock
- bakufu waterfall
- bama (-hama) beach, field
- bana (-hana) point
- bara (-hara) plain, field
- chō (-machi) township
- dai (-tai) plateau, plain
- dake (-take) mountain
- daki (-taki) waterfall
- dani (-tani) valley, stream
- gan (-iwa) rock, cliff
- gata bay, inlet, lake
- gawa (-kawa) river
- goe (-koe) mountain pass
- gun county
- guntō archipelago
- fuji mountain
- hae (-bae) rock
- hama (-bama) beach, field
- hana (-bana) point
- hantō peninsula
- hara (-bara) plain, field
- ike pond
- ishi rock, cliff
- iso rock, skoal
- iwa (-gan) rock, cliff
- jima (-shima, -tō) island
- kai (-umi) bay, gulf
- kaikyō strait
- kawa (-gawa) river
- ken prefecture
- ko lake
- kō harbor
- koe (-goe) mountain pass
- kojima small isle
- machi (-chō) township
- mine mountain
- misaki (-saki, -zaki) cape
- mori mountain, forest
- mura township
- nada sea
- no plain, field
- onsen hot spring, spa
- rettō island chain
- saki (-zaki, -misaki) cape
- san (-zan, -yama) mountain, ridge
- se reef, shoal, rapid
- seto strait
- shi municipality, city
- shima (-jima, -tō) island
- shō reef, shoal
- shotō island group
- suidō channel
- tai (-dai) plateau, plain
- take (-dake) mountain
- taki (-daki) waterfall
- tani (-dani) valley, stream
- tō (-shima, -jima) island
- tōge mountain pass
- uchi inlet
- umi (-kai) bay, gulf
- ura inlet, beach
- wan bay
- yama (-san, -zan) mountain, ridge
- yu mineral spring, spa
- zaki (-saki, -misaki) cape
- zan (-san, -yama) mountain, ridge

- ==== National Highway
- ==== Main Prefectural Roads
- ==== More than 3 Meters Wide
- ==== More than 2 Meters Wide
- ==== More than 1 Meter Wide
- ==== Less than 1 Meter Wide
- ==== Impassable for Carts
- ==== Tree-lined Roads: (A) Narrow (B) Wide
- ==== Power Lines along Road: (A) Ordinary (B) High Tension
- ==== Government Railways: (A) Two Tracks (B) Single Track (C) Station
- ==== Feeder Railways: (D) Double (E) Single
- ==== Boundaries: International
- ==== Prefectural (A) Fixed (B) Approximate
- ==== Province (Obsolete)
- ==== Gun, shi or Sub-prefectural
- ==== Ward, Machi or Mura (A) Fixed (B) Approx
- ==== Government Lands
- ==== Property Lines (A) Fixed (B) Approximate

Main surfaced roads; (a) - more than 4 meters wide; (b) - 2.4 meters wide		Graves; Chinese, native
Other surfaced roads		Cemetery; heathen, Christian
Unsurfaced roads, passable all seasons		Ruins; monuments
Unsurfaced roads, passable in dry season		Buildings; iron, stone, wooden, bamboo
(a) - pack trail; (b) - trail (a) - wood and stone distance posts; (b) - iron bridge; (c) - wooden bridge; (d) - bamboo bridge; (e) - wooden culvert; (f) - stone culvert; (g) - cut; (h) - fill; (i) - grade		Warehouses; stone, iron, wooden, bamboo
Plantation crossroads; road under construction		Government hostels
Railroad; (a) - station; (b) - under construction		Boundary markers; stone, wood, iron; signpost
Narrow gauge railroad; (a) - station; (b) - tramway, steam and electric		Fences; stone, barbed wire
(a) - settlement; (b) - sparsely settled area; (c) - cleared area		Hedges; living, dead
(a) - orchard or gardens; (b) - arable upland; (c) - wet rice field		Well; spring; fumarole; sulphur spring; running -spring
Salt pans; Administrative headquarters		Water tower; artesian well; stony river bed
Astronomical stations; electric power: lines		Marsh; swamp; mud spring
Telephone line; triangulation points		(a) - stream; (b) - unsurveyed stream; (c) - irrigation or drainage ditch; (d) - dry ditch
Christian church; mosque; Chinese temple		(a) - stone sluice; (b) - navigable; (c) - sandbank; (d) - ford; (e) - ferry; (f) - sandy shore
Radio station; airfield; oil tanks		Lake; fishponds
Piers or breakwaters; stone, iron, wood		(a) - dike, (b) - cut; (c) - island; (d and e) - direction of flow; (f) - fill; (g) - bank
Seawall; cofferdam		Contour interval 25 meters with every 10th contour heavy; (a) - depression contour; (b) - elevation figures; (c) - irrigated upland rice field; (d) - form line; (e) - slight elevation; (f) - rocky ground; (g) - irregular ground; (h) - line separating land always wet from dry land
Stone lighthouse; iron lighthouse; watch towers		(a) - cave; (b) - mine; (c) - tunnel
Drydock; floating drydock; warning signal		Forest; tree used as landmark; underbrush; mangrove
Anchorage; harbor; harbor lights		Grass; alang-alang grass; wild sugar cane
Buoys and beacons (various)		Plantations; rubber, tea, coffee
Rocks awash and under water, breakers; low water line		Trees of various types

GLOSSARY OF MAP TERMS

<i>Agonic line</i>	A line passing through points having no magnetic declination.
<i>Altitude tints</i>	See <i>Layer tints</i> .
<i>Annual change</i>	The yearly increase or decrease in magnetic declination.
<i>Arbitrary Grid</i>	A grid arbitrarily constructed and over-printed on a map and used to locate and designate map points without regard to their actual geographic location.
<i>Azimuth</i>	A direction usually expressed in degrees and usually measured clockwise from one of the three norths.
<i>Back azimuth</i>	Azimuth (\pm) 180° ; the reverse or backward direction of an azimuth.
<i>Bench mark</i>	A marker along a line of survey indicating elevation.
<i>Cadastral map</i>	A map of extremely large scale showing the exact position and dimensions of objects and real estate properties.
<i>Centigrade</i>	A 100th part of a grade; 100 decimilligrades; a unit of angular measure equal to 0.54 of a degree minute.
<i>Centimeter</i>	A measure of length equal to $1/100$ of a meter or approximately $2/5$ (0.3937) of an inch.
<i>Clinometer</i>	An instrument for measuring or indicating angles of slope and elevation.
<i>Compass</i>	An instrument for determining directions upon the earth's surface by means of a magnetized needle turning freely upon a pivot and pointing to the magnetic north and south.
<i>Compiled map</i>	A map prepared by assembling data from existing maps, photo maps, intelligence reports, reconnaissance, etc.
<i>Coniferous woods</i>	Woods composed of trees (generally evergreen) bearing cones.
<i>Contour interval</i>	The difference in elevation between two adjacent contour lines; vertical interval.
<i>Contour line</i>	An imaginary line on the surface of the earth (represented on maps by actual lines) all points of which are the same height above a datum plane.

<i>Convergence</i>	An elliptical expression of the British "angle of convergence"; grid declination. (See <i>Grid declination</i> .)
<i>Copied map</i>	A map reproduced from an existing map.
<i>Datum plane</i>	A plane or level used as a basis for reckoning altitudes. (Usually mean sea level on maps.)
<i>Deciduous woods</i>	Woods composed of trees (usually broad-leaved) which shed their leaves.
<i>Decimilligrade</i>	A 100th part of a centigrade; a unit of angular measure equal to 0.324 of a degree second.
<i>Declination protractor</i>	A map-orienting device, consisting of a horizontal degree scale and a pivot point, by means of which a magnetic north line may be drawn across the face of a map.
<i>Defiladed area</i>	An area not visible from a given point.
<i>Degree</i>	A 360th part of the circumference of a circle.
<i>Easting</i>	The eastward (that is, from left to right) reading of grid values; the X-coordinate of a British grid reference.
<i>False origin</i>	A fixed point to the south and west of a British grid zone from which grid lines are numbered eastward and northward; the origin of grid values.
<i>Form line</i>	An approximate contour, shown on a map as a dotted or broken line, used to depict elevation in the absence of contours or between widely spaced contour lines.
<i>Geodetic surveying</i>	The branch of surveying which takes into account the curvature of the earth.
<i>Grade</i>	A 400th part of the circumference of a circle; a unit of angular measure equal to 9/10 of a degree.
<i>Gradient</i>	A slope expressed as a fraction, for example, a gradient of 1/30 represents a rise or fall of one unit of linear measure in a distance of 30 like units of measure. (Formula for computing gradient between two points: $\frac{\text{Vertical Difference}}{\text{Horizontal Distance}} = \text{Gradient.}$)
<i>Graphic scale</i>	A graduated line on the margin of a map, by means of which distances on the map may be measured in terms of actual ground distances.
<i>Graticule</i>	A four-sided figure on a map formed by the intersection of two meridians and two parallels.

<i>Grid azimuth</i>	An azimuth measured from grid north.
<i>Grid declination</i>	The angular difference between grid north and true north measured east or west from true north.
<i>Grid junction</i>	The boundary between two grid zones, sometimes emphasized by shading.
<i>G-M angle</i>	The angular difference between magnetic north and grid north measured east or west from grid north; sometimes referred to on United States maps as magnetic declination from grid north.
<i>Grid north</i>	The north toward which the vertical grid lines on a map point.
<i>Grid zone</i>	An area covered by grid lines based on one origin, and for which area grid tables have been prepared for use in the computation of geographic coordinates.
<i>Hachuring</i>	A system of depicting relief by means of short disconnected lines drawn in the directions of steepest slope.
<i>Hill shading</i>	A system of depicting relief on a map by means of shadows caused by an imaginary oblique light assumed to be shining on the map from a northerly direction.
<i>Hypsometric diagram</i>	A small-scale diagram representing relief by means of different patterns or degrees of shading for specified levels of elevation.
<i>Intersection</i>	A method of locating a point by plotting the azimuths to that point from two or more known fixed points. (The intersection of these azimuths indicates the location of the point.)
<i>Isogonic line</i>	A line passing through points of equal magnetic declination.
<i>JAN Grid (Joint Army-Navy Grid)</i>	A point designation grid used jointly by United States land and naval forces. (Described in TB 21-25-1, 2 Mar 44.)
<i>Kilometer</i>	A unit of linear measure approximately $\frac{5}{8}$ (0.62) of a mile; 1,000 meters.
<i>Latitude</i>	The angular distance in degrees north or south of the equator.
<i>Layer tints (altitude tints)</i>	A system of depicting relief by use of different colors and tints to indicate specified levels of altitude.

<i>Longitude</i>	The angular distance in degrees east or west of a prime meridian.
<i>Magnetic azimuth</i>	An azimuth measured from magnetic north.
<i>Magnetic declination</i>	The angular difference between magnetic north and true north measured east or west from true north.
<i>Magnetic north</i>	The north toward which the needle of a compass points.
<i>Map</i>	A representation of a portion of the earth's surface drawn to a definite scale and depicted on a flat surface.
<i>Map orientation</i>	The act of placing a map so that its north lines point to their corresponding norths. (The British call this process "setting a map".)
<i>Map template (map templet)</i>	A thin transparent plate divided into grid squares of a definite size and used for point designation purposes.
<i>Meridian</i>	Half of a great circle passing through the poles; one of a series of imaginary lines of longitude extending from pole to pole and the representation of such a line on a map.
<i>Metalled road</i>	A road constructed of gravel, crushed stone, slag, or similar material with a binder of fine aggregate, tar, or cement.
<i>Meter</i>	A unit of linear measure approximately 39.37 inches; the basic unit of measure of the metric system.
<i>Mil</i>	A 6400th part of the circumference of a circle (1° equals approximately 17.78 mils.)
<i>Millimeter</i>	1/1000 of a meter; a metric measure approximately 0.039 of an inch.
<i>Northing</i>	The northward (that is, from bottom to top) reading of grid values or the Y-coordinate of a British grid reference.
<i>Parallel</i>	One of a series of imaginary circles on the surface of the earth, parallel to the equator, marking the latitude; also the representation of such a line on a map.

<i>Percent of slope</i>	The angle of ascent or descent expressed as a percent; the number of linear units a slope rises or falls vertically in a horizontal distance of 100 like units. (Formula for computing percent of slope between two points: $\frac{\text{Vertical Difference}}{\text{Horizontal Distance}} \times 100 = \text{Percent of Slope.})$
<i>Photomap</i>	A reproduction of a aerial photograph or mosaic upon which grid lines, marginal data, and place names may be added.
<i>Plan</i>	A map, usually of a city or a small area, having an extremely large representative fraction (RF).
<i>Plane table map</i>	A large-scale map depicting objects and their distances from each other horizontally and vertically; a map made without considering the effect of the curvature of the earth. (It differs from a planimetric sketch in that it depicts relief.)
<i>Planimetric sketch</i>	A sketch depicting objects and their distances from each other horizontally without regard to their elevation.
<i>Polar coordinates</i>	A means of designating a point by stating its direction and distance from a known reference point.
<i>Prime meridian</i>	A meridian from which longitude is measured, both east and west; the meridian line at which longitude is zero.
<i>Profile</i>	A cross section of a portion of the earth's surface formed by the intersection of the earth's surface with an imaginary vertical plane.
<i>Projection</i>	Any one of a number of systems of parallels and meridians upon which a map can be drawn.
<i>Quadrant</i>	One of the four parts into which a plane is divided by vertical and horizontal axes.
<i>Relief</i>	The representation on a map of ground forms, such as ridges, valleys, mountains, etc.
<i>Representative fraction (RF)</i>	The relationship between map distance and ground distance expressed as a ratio, for example, 1:25,000 or 1/25,000.
<i>Resection</i>	A method of locating a point by plotting the back azimuths to that point from two or more known fixed points. (The intersection of these back azimuths indicates the location of the point.)

<i>Scale</i>	The relationship between map distances and ground distances expressed in one or more of the following ways: words and figures, representative fractions, and graphic scales.
<i>Scale factor</i>	The value by which an actual ground distance is multiplied to obtain that ground distance as represented on a map. (This factor compensates for map distortion.)
<i>Spot height</i>	The printed figure on a map which designates the elevation of a point above a datum plane; spot elevation.
<i>Survey</i>	The determination and delineation of the form, extent, and position of portions of the earth's surface, accomplished by measuring linear and angular distances and the application of the principles of triangulation.
<i>TAD Grid (Target-Area Designator Grid)</i>	A system of grid reference, applicable to maps using a 1,000-yard World Polyconic grid, which identifies 200-yard squares by a four-digit number and a letter.
<i>Terrain intelligence</i>	The understanding and appreciation of the topographic nature of terrain and the evaluation of its potential effect on military operations.
<i>Topographic map</i>	A map depicting objects and their distances from one another horizontally and vertically; a map depicting relief.
<i>Triangulation point</i>	A point whose precise elevation and geographic position is known; primary traverse station; trigonometrical point (British).
<i>True north</i>	The direction of the geographic north pole from any point on the earth's surface; geographic north.
<i>True origin</i>	The intersection of the central meridian and the median parallel of a British grid zone. (This intersection determines the directions, for example, north-south and east-west, of the grid lines covering the zone in question.)

BIBLIOGRAPHY

- Arendt, Lieut.-Colonel Breveté: *Aide-Mémoire de l'Officier de Réserve d'Infanterie*, 10th ed., 1934, Bordeaux.
- Raisz, E.: *General Cartography*, 1938, McGraw-Hill Book Company, Inc., New York.
- Rigg, Capt. Robert B.: "Approach to Foreign Map Reading," Part I, *The Military Engineer*, August, 1942, Washington, D. C.
- Rigg, Capt. Robert B.: "Approach to Foreign Map Reading," Part II, *The Military Engineer*, December, 1942, Washington, D. C.
- Steppe, J. J.: "Maps of the Japanese Army," translated from the Russian; *Geodesist: Scientific-Technical and Productive Journal*, Joint Scientific-Technical State Publication, No. 12, 1935.
- Command and General Staff School: *French Maps*, 1933 (Reprinted, 1943. Changes No. 1, 1935, and No. 2, 1943, included.), Fort Leavenworth, Kans.
- Joint Intelligence Study Publishing Board: *Joint Army-Navy Intelligence Study of Southwest Japan: Kyushu, Shikoku, and Southwestern Honshu*, Vol. I, Ch. XV, Gazetteer and Map Appraisal (Restricted), 1944.
- Camp Savage, Minnesota: *Heigo Textbook*, Vol. IV, February, 1943.
- Research Section, The Engineer School: "Thrust Line Method of Map Reference (German)," *Research Weekly Digest* No. 5, January 4, 1943, Fort Belvoir, Va. (Restricted).
- Research Section, The Engineer School: "Method of Reading British Maps," *Research Weekly Digest*, No. 9, February 1, 1943, Fort Belvoir, Va. (Restricted).
- U. S. Lake Survey, Military Grid Unit: "Geodetic Work in Japan," December, 1944.
- War Department, Army Map Service, Corps of Engineers, U. S. Army: "Grids and Magnetic Declinations," *Army Map Service Memorandum No. 425*, 3d ed., September, 1943, Washington, D. C.
- War Department, Army Map Service, Corps of Engineers, U. S. Army: *Glossary of Selected Map Terms Relative to Authorities, Dates, Scales, Editions, and Locations in Foreign Text Maps*, March, 1944, Washington, D. C.
- War Department, Military Intelligence Service: "Reading a Japanese Map," *Tactical and Technical Trends*, June 1, 1944, Washington, D. C. (Restricted).

War Department: "Use of Foreign Maps," *Tentative Technical Manual*, November 5, 1942, Washington, D. C.

War Office: *Manual of Map Reading, Photo Reading, and Field Sketching*, 1940, His Majesty's Stationery Office, London.

Sources of Information on Foreign Conventional Signs

Command and General Staff School: *French Maps*, 1933 (Reprinted, 1943. Changes No. 1, 1935, and No. 2, 1943, included.), Ft. Leavenworth, Kans.

War Department, Army Map Service, Corps of Engineers, U. S. Army: *Legends for Netherland Indies Topographic Maps*, 1943, Washington, D. C.

War Department, Army Map Service, Corps of Engineers, U. S. Army: *Symbols Appearing on Original Chinese Maps, Scales 1:10,000, 1:25,000, 1:50,000*, September, 1944, Washington, D. C.

War Department, Army Map Service, Corps of Engineers, U. S. Army: *Symbols Used on Chinese General Staff Maps*, November, 1943, Washington, D. C.

War Department: *FM 30-22, Foreign Conventional Signs and Symbols*, July 7, 1942, Washington, D. C. (Restricted).

War Department: *TM 30-410, Handbook on the British Army*, September 30, 1942, Washington, D. C. (Restricted).

War Department: *TM 30-480, Handbook on Japanese Military Forces*, September 21, 1942, Washington, D. C. (Restricted).

War Office: *Manual of Map Reading, Photo Reading, and Field Sketching*, 1940, His Majesty's Stationery Office, London.